

INFORMATION TO USERS

This manuscript has been reproduced from the microfilm master. UMI films the text directly from the original or copy submitted. Thus, some thesis and dissertation copies are in typewriter face, while others may be from any type of computer printer.

The quality of this reproduction is dependent upon the quality of the copy submitted. Broken or indistinct print, colored or poor quality illustrations and photographs, print bleedthrough, substandard margins, and improper alignment can adversely affect reproduction.

In the unlikely event that the author did not send UMI a complete manuscript and there are missing pages, these will be noted. Also, if unauthorized copyright material had to be removed, a note will indicate the deletion.

Oversize materials (e.g., maps, drawings, charts) are reproduced by sectioning the original, beginning at the upper left-hand corner and continuing from left to right in equal sections with small overlaps.

Photographs included in the original manuscript have been reproduced xerographically in this copy. Higher quality 6" x 9" black and white photographic prints are available for any photographs or illustrations appearing in this copy for an additional charge. Contact UMI directly to order.

**ProQuest Information and Learning
300 North Zeeb Road, Ann Arbor, MI 48106-1346 USA
800-521-0600**

UMI[®]

**Developing a Multi-Attribute Utility Model (MAUM) for selecting
information technologies in the construction industry**

by

Tarek Elsayed Elmisalami

**A dissertation submitted to the graduate faculty
in partial fulfillment of the requirements for the degree of**

DOCTOR OF PHILOSOPHY

Major: Civil Engineering (Construction Engineering and Management)

Major Professor: Edward Jaselskis

Iowa State University

Ames, Iowa

2001

UMI Number: 3034179

UMI[®]

UMI Microform 3034179

**Copyright 2002 by ProQuest Information and Learning Company.
All rights reserved. This microform edition is protected against
unauthorized copying under Title 17, United States Code.**

**ProQuest Information and Learning Company
300 North Zeeb Road
P.O. Box 1346
Ann Arbor, MI 48106-1346**

**Developing a Multi-Attribute Utility Model (MAUM) for selecting
information technologies in the construction industry**

by

Tarek Elsayed Elmisalami

**A dissertation submitted to the graduate faculty
in partial fulfillment of the requirements for the degree of
DOCTOR OF PHILOSOPHY**

Major: Civil Engineering (Construction Engineering and Management)

**Program of Study Committee:
Edward Jaselskis, Major Professor
Johanshir Golchin
Anthony Hendrickson
Kandiah Jeyapalan
Russell C. Walters**

Iowa State University

Ames, Iowa

2001

Graduate College
Iowa State University

This is to certify that the Doctoral dissertation of
Tarek Elsayed Elmisalami
has met the dissertation requirements of Iowa State University

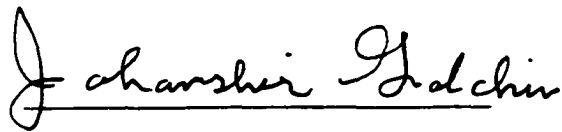

Committee member



Committee member



Committee member



Committee member



Major Professor

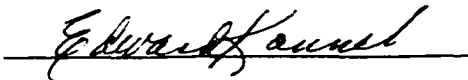

For the Major Program

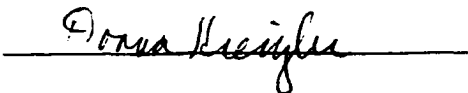

For the Graduate College

TABLE OF CONTENTS

TABLE OF FIGURES	vi
LIST OF TABLES	vii
LIST OF TABLES	vii
ACKNOWLEDGEMENTS	viii
CHAPTER 1. INTRODUCTION.....	1
1.1-Overview	1
1.2-The Rationale for Multi Attribute Utility Theory	4
1.2-Problem Statement.....	5
1.3-Research Objective	5
1.4-Methodology	6
1.5-Organization of this Study	8
CHAPTER 2. THE MULTI-ATTRIBUTE UTILITY THEORY.....	10
2.1-The MAUT and Principal of Decomposition	10
2.2-The Hierarchical Structure of the MAUT	11
2.2.1-Defining evaluation objectives.....	11
2.2.2-Defining alternative attributes.....	12
2.2.2.1-Attribute characteristics	12
2.2.2.2-Number of attributes.....	13
2.2.3-Uncertainty in the model	14
2.2.3.1-Methods of incorporating uncertainty in the model	14
2.2.4-Determining single-attribute utilities	17
2.2.5-Assigning attribute weights.....	17
2.2.6-Checking attribute utility independence	17
2.2.7-Utility aggregation rules	20
2.2.7.1-Additive rule.....	20
2.2.7.2-Multiplicative rule.....	21
2.2.8-The aggregate utility function.....	29
CHAPTER 3. DEVELOPING A MODEL THAT SELECTS AMONG DIFFERENT BAR CODE AND RFID SYSTEMS IN CONSTRUCTION MATERIAL TESTING LABS.....	31
3.1- Defining Sample Identification and Data Recording Problems in Construction Material Testing Labs	33
3.1.1-Type of work in construction materials testing labs.....	33
3.1.2-Current data recording procedure	34
3.1.3-Data recording process inefficiency	36
3.1.4-Identifying opportunity for improvement	37

3.1.5-An overview of bar code and RFID technologies	37
3.1.5.1-Bar code system components	37
3.1.5.2-RFID system components	38
3.1.6-The problem of selecting the data capture system.....	39
3.2- Identifying and Screening Data Capture Technology Alternatives.....	40
3.3- Systems Evaluation Objectives	44
3.4- Determining Attributes	45
3.4.1-Initial attribute list	45
3.4.2-Process of excluding some attributes from the model.....	45
3.4.3-Explanation of model attributes.....	50
3.5-Defining Attribute Measuring Scales.....	56
3.6-Measuring Weights.....	58
3.7-Checking Attribute Utility Independence.....	60
3.8-Procedure of Constructing Single-Attribute Utility Functions	61
3.8.1-Quantitative attributes	61
3.8.2-Qualitative attribute utilities	63
3.9- Calculating Lower Level Objective Utilities	63
3.10-Determining Objective Interactions.....	65
3.11-Model Aggregation	66
3.12-Limitations of the Study	67
CHAPTER 4. MODEL RESULTS AND ANALYSIS	70
4.1-Summary Results	70
4.2-Sensitivity Analysis	74
4.2.2-Effect of changing system prices	75
4.2.3-Effect of changing the model integration rules	76
4.3-Differences between Government and Private Labs	80
4.3.1-PDT system rankings for the IDOT and private labs	80
4.3.2-Differences in viewing model relationships	82
4.3.3-Differences in viewing attribute importance	82
4.3.4-Differences in quantitative and qualitative attribute utilities	83
4.4-Differences between ITPs and Technicians	84
4.4.1-PDT system rankings for ITPs and technicians.....	84
4.4.2-Differences in viewing model relationships	88
4.4.3-Differences in viewing attribute importance	89
4.4.4-Differences in quantitative attribute utilities.....	93
4.4.4.1-Differences in utility curves for ITPs and technicians.....	99
4.4.5-Differences in qualitative attribute ratings	101
CHAPTER 5. SUMMARY, RECOMMENDATIONS, AND CONCLUSIONS	105
5.1-Summary	105
5.2-Recommendations.....	109
5.3-Conclusions.....	110

APPENDIX A. SUMMARY OF PREVIOUS RESEARCH RELATED TO BAR CODE AND RFID IN THE CONSTRUCTION INDUSTRY	112
APPENDIX B. BAR CODE TECHNOLOGY	113
APPENDIX C. RFID TECHNOLOGY	117
APPENDIX D. SIMILAR USES OF BAR CODE AND RFID TECHNOLOGIES IN THE CONSTRUCTION INDUSTRY	123
APPENDIX E. DATA SURVEY	128
APPENDIX F. UTILITY CURVES AND EQUATIONS FOR QUANTITATIVE ATTRIBUTES IN OVERALL SAMPLE	145
APPENDIX G. SUMMARY OF INTERMEDIATE AND AGGREGATE UTILITY CALCULATIONS.....	149
APPENDIX H: SUMMARY OF THE MAUM CALCULATIONS.....	151
REFERENCES CITED	157

TABLE OF FIGURES

Figure 1. Methods of incorporating uncertainty in MAUM.....	15
Figure 2. The analogy between utility independence and hypothetical lotteries.	19
Figure 3. The additive rule and the concept of lottery indifference	20
Figure 4. Interpreting the attribute interactions using hypothetical lotteries.....	24
Figure 5. Using hypothetical lotteries on x-y axis to interpret the interaction between two utility attributes	26
Figure 6. Calculations of indifference probabilities	27
Figure 7. Current test data recording process at IDOT laboratory.....	35
Figure 8. Process of screening different data capture systems.....	42
Figure 9. Some bar code and RFID data collectors	44
Figure 10. Variations in attribute ranges.....	59
Figure 11. Verifying utility independence.....	60
Figure 12. A sample question to construct the reading distance utility function.	64
Figure 13. Example of using the hypothetical lottery to calculate the interaction weights using the indifference probabilities.....	65
Figure 14. Final form of the model including the interaction relationships.....	67
Figure 15. Systems ranking for overall sample	71
Figure 16. Capability, reliability, and technical merit utilities.....	72
Figure 17. Cost, risk, and economic merit utilities	73
Figure 18. Technical merit, economic merit, and aggregate utilities.....	74
Figure 19. Aggregate utilities using the additive and multiplicative rule	76
Figure 20. Technical merit utilities using the additive and multiplicative rules	77
Figure 21. Economic merit utilities using the additive and multiplicative rules....	77
Figure 22. Six types of data comparisons in this study.....	80
Figure 23. Aggregate utilities for IDOT and private labs.....	81
Figure 24. Aggregate utilities for ITPs and technicians	85
Figure 25. Technical merit utilities for ITPs and technicians.....	86
Figure 26. Economic merit utilities for ITPs and technicians	88
Figure 27. Differences in the rankings of capability attributes by ITPs and technicians at IDOT, private labs, and the overall sample	94
Figure 28. Differences in the rankings of reliability attributes by ITPs and technicians at IDOT, private labs, and the overall sample	95
Figure 29. Utility curves for quantitative attributes in overall sample.....	100
Figure 30. Some examples of one-dimensional bar code symbologies	114
Figure 31. Stacked bar code	115
Figure 32. Two-dimensional matrix bar code.	116
Figure 33. Tags manufactured by Trovan and Intermec.....	118
Figure 34. The Intermec Sabre 1555, and Trovan GR 68 readers	119
Figure 35. Bechtel worker receiving pipe hangers using RFID approach.....	124
Figure 36. NIST web site to track construction components	125
Figure 37. Utility curves for quantitative attributes in overall sample.....	145
Figure 38. Example of indifference probabilities calculations	152
Figure 39. Example of the model calculation.....	156

LIST OF TABLES

Table 1. Material testing labs participating in the study	31
Table 2. Initial attribute list.....	47
Table 3. Objectives and attribute hierarchy as included in the final model	51
Table 4. Description of system attributes	57
Table 5. The indifference probabilities and the interaction weights	88
Table 6. Attribute weights by ITPs and technicians at the IDOT, private labs, and in the overall sample	90
Table 7. Quantitative attribute utilities measured at five points	96
Table 8. Significant differences in utilities for ITPs and technicians at the IDOT, private labs, and in the overall sample	103
Table 9. Summary of intermediate and aggregate utility calculations for ITP at IDOT, private labs, and in the overall sample.....	149
Table 10. Summary of intermediate and aggregate utility calculations for technicians at IDOT, private labs, and in the overall sample.....	150

ACKNOWLEDGEMENTS

I would like to express my deep thanks to Dr. Edward Jaselskis, the major professor, for devoting a great deal of his time and effort to provide me with valuable guidance and advice. All his support as a professor and friend will always be remembered.

I would also like to thank my committee members: Dr. Johanshir Golchin, Dr. Anthony Hendrickson, Dr. Kandiah Jayapalan, and Dr. Russell Walters for their support and encouragement. I will always remember their nice personnel and characters. I wish to express my appreciation to Dr. Charles Jahren, Dr. Edward Minchin, and Dr. James Rowings who were also involved in my committee.

It is not possible to thank individually all those who contributed in some way to the preparation of this research. However, it must be reported that many people cheerfully contributed their time and effort to have this job completed.

Special credit must go to my wife and daughters for their patience and understanding. They have stood firm behind me throughout my graduate studies sacrificing precious hours I could have offered them.

CHAPTER 1. INTRODUCTION

1.1-Overview

The construction industry lags behind other industries in adopting innovative new technologies. The need to accelerate the rate of technological adoption in the construction industry has been well identified and documented in the literature (Mitropoulos and Tatum, 2000). This adoption comes from continuously seeking, recognizing, and implementing new technologies that improve construction processes (Laborde and Sanvido, 1994).

Teicholz (1994) recommended updating the current construction procedures used to transfer data and information by taking advantage of new information technology (IT) opportunities. The term “information technology” encompasses all aspects of computing, networking, and communications technologies applied to the generation and use of information in the planning and operation of all kinds of tasks (Feeser, 2001). Because advanced ITs are now available, the construction industry is in a position to make significant progress in enhancing construction operations.

In fact, so many new ITs now exist that industry managers are often confounded when they plan a new system (Jung and Gibson, 1999). This situation requires new approaches of evaluating ITs.

Much IT research focuses on assessing IT's value and understanding the determinant of that value. Researchers have developed many approaches to help firms select their IT resources more wisely.

In evaluating ITs, many researchers emphasize the economic characteristics of the technology. For example, most of the earlier work that evaluated ITs relied on financial models concentrating on firm-wide strategies for maximizing the return of investment (Mora and Weber, 1999). Techniques such as the *net present value* (NPV), *internal rate of return* (IRR), and payback period are used to select the technology that yields the highest expected payoff. Other economic decision criteria include the *maximin* criterion in which decision makers maximize the minimum possible payoff or minimize the possible losses. In other words, decision makers select the best of the worst possible outcomes. On the other hand, in the *minimax regret criterion*, decision makers attempt to minimize the regret that they may experience after the selection (Burton et al, 1986).

Other researchers took a second approach and studied whether the technology was critical for organizational performance (Nord and Tucker, 1987). Mitropolous and Tatum (2000) reported that many researchers agreed that the diffusion of a new technology depends

primarily on its attributes without the researchers identifying whether or how these attributes interact to influence the technology's adoption.

A third approach to IT evaluation attempts to understand the determinants of IT usage. For example, the Technology Acceptance Model (TAC) specifies that perceived usefulness and perceived ease of use are determinants of user satisfaction. The intention of use depends on user expectations about whether a particular technology will result in enhanced job performance with reduced effort.

The user's intention to use a technology is modeled as a weighted linear function of his attitude toward technology's perceived usefulness and ease of use. The relationship implies that the easier the technology is to use and the more useful it is perceived to be, the more pronounced the user's intention to use the technology (Davis et al, 1989). The correlation between the intention and perception of usefulness and ease of use determines the extent to which the intention is indicative of the model's validity.

A Likert-type questionnaire is used to elicit the end user's perception of whether the technology will enable him to accomplish tasks more quickly, improve his performance, increase his productivity, enhance his effectiveness, and make his job easier. On the other hand,

the perception of ease of use is addressed by such questions as whether learning technology is easy, flexible, and interactive.

Information technology research has been constrained by a shortage of high-quality measures of key determinants of IT user acceptance (David et al, 89). Mora and Weber (1999) point out that because assessing the value of IT is still a controversial subject in the literature, there is a need to develop a sound planning and evaluation methodology for IT programs that reduces IT investment risk and facilitates more accurate planning.

Because the major roadblock to evaluating alternative ITs is the complexity of the selection decisions, this research attempts to develop a decision tool ensuring that IT decisions are easily and rationally evaluated in the construction industry.

1.2-The Rationale for Multi Attribute Utility Theory

The preceding evaluation methods focus on one type of user satisfaction: whether it is based on economic considerations or on the user's perception of the technology's usefulness and ease of use. Economic factors, and user's perception are only some of many relevant measures of IT usage success. Limiting the selection problem to one of these approaches could lead to unwise decisions. For example, a

technology might be user friendly but not economical, or economical but very complicated.

This research suggests another robust type of IT evaluation based on the multi-attribute utility theory (MAUT). The appeal of MAUT is that it combines technical, economic, and risk factors into one aggregate utility index. User perception of all of these factors is implied in the evaluation of utilities. Moreover, the existing models, unlike MAUT, do not establish systematic procedures for selecting IT.

1.2-Problem Statement

Because the use of ITs in the construction industry is of primary importance today, decision makers in many construction applications often face technology selection issues. There are hundreds of ITs on the market. Each technology has its own technical, economic, and risk considerations that make the selection process a difficult one. The selection decision involves many tradeoffs among technology attributes. Rarely is an alternative simultaneously best in all attributes, placing a burden on construction decision makers. Currently there is no tool that rationalizes and facilitates this complicated decision-making process.

1.3-Research Objective

The primary objective of this research is to develop a decision tool that helps decision makers select and evaluate the appropriate IT for

construction applications. This systematic evaluation methodology will be based upon the “Utility” theory and referred to as the Multi-Attribute Utility Model (MAUM).

The contributions of this research are many fold. First, the model introduces a robust decision tool not yet used for construction applications that can successfully be implemented in many engineering and project management selection issues. For example, the model can evaluate a wide variety of construction alternatives such as equipment, construction methods, project types, bids, and technologies.

Second, the research focuses on one application: selecting the best bar code and Radio Frequency Identification (RFID) system as examples of data capture technologies for construction material testing laboratories. Moreover, the study intends to evaluate the differences between the preferred technologies as well as the most important technology attributes favored by Information technology professionals (ITPs) and technicians in government and private testing labs. Furthermore, the research examines the common belief that RFID systems are always superior to bar code systems.

1.4-Methodology

There are four distinct stages to this research. In the first stage, the multi-attribute utility theory (MAUT) was carefully examined. The

theory is suitable, robust, and flexible because it allows one to combine all of the evaluation concerns about the technology under investigation, such as technical, economic, and risk factors. An extensive study of the usefulness, robustness, and limitations of this theory was also made in this stage.

In the second stage, bar code and RFID technologies were selected as examples of ITs where many decision makers struggle to select the best configurations for their needs. A comprehensive literature review resulted in an understanding of the different configurations of bar code and RFID systems on the market.

The third stage involved approaching many construction organizations that currently have or expect to have data capture technology selection issue. This effort resulted in the selection of six construction material testing labs in Iowa. This stage involved (1) understanding the current sample identification and test data recording system, and (2) identifying the appropriate technology alternatives for these labs. Technologies' attributes were elicited to distinguish among different alternatives. A survey was designed to elicit the needs and preferences of both lab technicians and ITPs at these labs. These preferences were then analyzed and quantified to build the model's structure.

The fourth stage involved the model formation, calculations, and analysis using the data obtained in the third stage. This stage revealed the technology's most important attributes according to lab decision makers, produced decision makers' utility curves, and calculated intermediate and aggregate utilities for technology alternatives. Merit rankings for ten of the most common data capture systems (5 bar code and 5 RFID systems) were developed. Sensitivity analysis was also performed to better understand the dynamics of the technology selection process and to provide recommendations.

1.5-Organization of this Study

To develop a model that evaluates the use of ITs in the construction industry, Chapter 2 introduces the MAUM. Chapter 3 explains the model development process for evaluating bar code and RFID systems in construction material testing labs. Chapter 4 presents the results and discusses them, and Chapter 5 presents the summary, recommendations, and conclusions.

Supplementary materials are also available in the Appendixes. Appendix A reviews previous literature related to bar code and RFID in the construction industry. Appendix B presents a brief background of bar code technology. Information about RFID technology and its limitations is found in Appendix C. Appendix D reviews some

applications where bar code and RFID systems compete to serve certain construction operations. Appendix E contains the survey questions used to develop the model's structure. Appendix F shows some of the users' utility curves that are used in this analysis. Appendix G provides a summary of intermediate and aggregate utility calculations. Appendix H outlines the model calculation procedure.

CHAPTER 2. THE MULTI-ATTRIBUTE UTILITY THEORY (MAUT)

During the last two decades, the use of MAUT to evaluate rival options has become an accepted practice throughout government and industry (Bard et al., 1989). The MAUT has also been explored in other fields' literature such as economics, behavioral research, and industrial engineering, but so far it has no uses in the construction world. The MAUT is introduced in this study, because it provides a good systematic approach for evaluating different construction alternatives. The MAUT methodology helps decision makers compare and select among complex alternatives (Geoffrion et al., 1972). The procedures described in this chapter explain the general framework of the theory.

2.1-The MAUT and Principal of Decomposition

When the evaluation problem has multiple dimensions, intuitive judgments may become exceedingly difficult. To facilitate the decision-making process in such complex problems, the MAUT was developed. Authors have also called this tool of utility measurement MAUM and MAUA. Though the final letter is different, all of the terms refer to the same idea. The letter "T" may refer to technology or theory; "M" refers to measurement; and "A" refers to analysis (Winterfeldt and Ward, 1986).

The theory's basic idea is that the selection issue can be broken down into alternative attributes. Based upon the user's tradeoffs among attributes, importance weights are quantified and single-attribute utilities are measured. Finally, single-attribute utilities are combined to develop with one single aggregate utility index for each alternative. The main consideration is how to structure and assess an aggregate utility function such that:

$$u(x_1, x_2, \dots, x_n) = f[u_1(x_1), u_2(x_2), \dots, u_n(x_n)], \quad \text{Equation 1}$$

Where U_i designates a utility function over single attribute x_i

Since the formal proofs appear in the literature, the discussions in this chapter will merely attempt to illustrate the plausibility of the concepts without delving into too many mathematical proofs. The next sections discuss some important concepts of the MAUT.

2.2-The Hierarchical Structure of the MAUT

2.2.1-Defining evaluation objectives

The evaluation theme in the MAUM model is based upon how much each alternative's attributes achieve the objective of the comparison. Organizing the model in a hierarchical structure is a good way to define different levels of objectives. The high-level objectives represent overall objectives. Then each high-level objective may branch

into a number of low-level objectives that are finally defined in terms of alternative attributes.

The relationship between objective levels is such that the low-level objectives should answer the question, “How should the high-level objective be realized?” The answer to the question, “Why is the low-level objective important?” confirms the relevance of the low-level objectives to its higher level. Iterating such questions and answers identifies unexpected gaps in the model’s structure (Pitz, 1984).

2.2.2-Defining alternative attributes

To capture and quantify all that is meant by an objective, several attributes might be defined under each objective. Attributes represent the lowest level of the objective hierarchy. Those attributes are the indicators that measure how each alternative succeeds in meeting the objectives. Because each alternative should have at least one attribute that is not available in other options, each alternative must make unique contributions to the evaluation objectives.

2.2.2.1-Attribute characteristics

Once a satisfactory level of determining the attributes is reached, the quantification process begins by defining suitable attribute measures. For example, the “cost” attribute is measured in dollars. Unfortunately, not all attribute measures are quantifiable. However, those non-quantifiable attributes can be defined in a subjective way. An

example of non-quantifiable attributes would be the “friendly use of a new technology.” The subjective ratings for this attribute would depend on the personal judgment of the decision maker.

Subjective attribute scales might have some sort of systematic bias and unreliability; however, they are not necessarily inferior to non-subjective measures (Campbell, 1975). Bias arises as much from the way scale scores are used as from the method of generating them (Pitz, 1984). Subjective attributes have the advantage of being inexpensive and fast. They are of a great help when non-subjective measures are not available for certain attributes. Subjective measures also save time and money when the process of developing similar non-subjective measures is too complicated or not direct.

2.2.2.2-Number of attributes

All attributes that can achieve the evaluation objectives must be considered, whether they are subjective or non-subjective attributes, as long as the decision maker views them as valid, appropriate, and credible. The problem with too many attributes is that they make the analysis cumbersome. Thompson (1982) recommended that no more than 15 to 20 attributes be analyzed. When alternatives have too many important attributes, the analyst should focus on the most important ones.

2.2.3-Uncertainty in the model

The validity of the information used in the evaluation process can be questioned (Cook and Campbell, 1979). Whether the current available information about evaluated options and their attributes can really predict the future performance of the alternatives is uncertain. For example, the success of one technology in a construction application does not guarantee that the same technology will produce the same results considering different time frames, users, or environments or construction sites.

2.2.3.1-Methods of incorporating uncertainty in the model

The decision of whether to consider uncertainty in the model or ignore it to simplify the analysis must be made in the early stages of model development. As a rule, if the absence of uncertainty in the model affects the decision, it should be considered.

Uncertainty can be included in the evaluation model in many implicit or explicit ways. The next sections discuss three of these methods. The first two methods are implicit approaches to incorporating uncertainty in the model quantification process. The third method is explicit, because certainty is included as an additional attribute for each technology. Figure 1 summarizes the three methods of incorporating uncertainty to the model.

2.2.3.1.1-Adjusting attribute utility in the quantifying stage

The simplest way to consider uncertainty in the model is ignore it in the modeling stage and to implicitly incorporate it in the quantification stage. The uncertain attribute utility for an option is rated less than in the case of certainty, implying uncertainty consideration.

Adjusting the attribute ratings or utility levels is an acceptable approach if involving uncertainty in the model is not very important or if the model structure is so complex that explicitly adding uncertainty in the model makes it too complicated to be developed and utilized (Pitz and Killip, 1984).

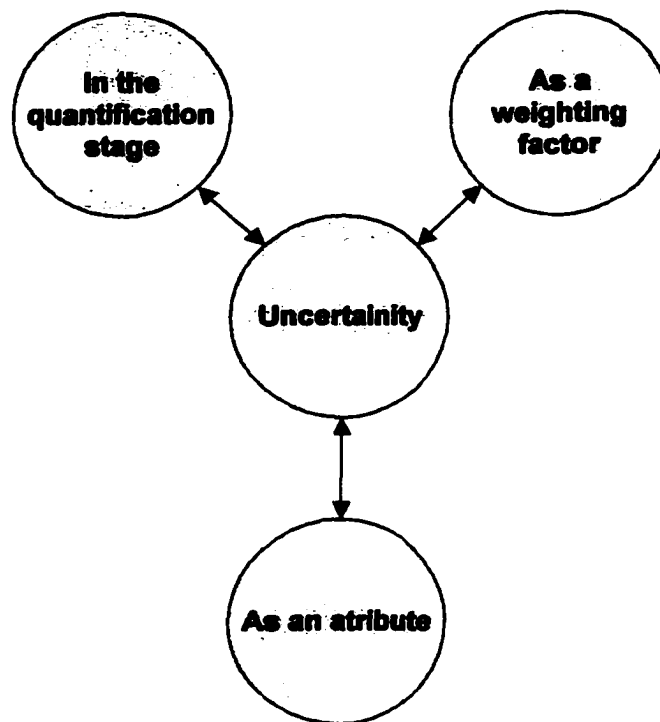

Figure 1. Methods of incorporating uncertainty in MAUM

2.2.3.1.2-Incorporating uncertainty in the attribute weightings

There also might be some concerns about the validity or the relevance of one of the attributes, considering the objectives. For example, the reading speed of a bar code scanner might be more important feature at a point-of-sale in a department store more than it is in a small warehouse that only contains a few bulk items. In this case, it is certain that the reading speed is a relevant attribute at the point-of-sale. Because of the uncertainty of the importance of the “reading speed” attribute in the warehouse case, the weight of the attribute should be lower than it is in point-of-sale applications, which certainly requires high reading speed.

2.2.3.1.3-Including uncertainty as a characteristic attribute

Introducing uncertainty as one or more of the option attributes enables the evaluator to express uncertainty in an explicit form. It is possible that reducing uncertainty might be one of the model objectives or attributes. For example, uncertainty can be viewed as a technology attribute. Each technology can be rated in terms of the level of uncertainty that it engenders. The best rate is assigned to the technology with the lowest level of uncertainty. This method avoids the explicit definition of uncertain outcomes and frees the evaluator from worrying about the probability of uncertain consequences.

2.2.4-Determining single-attribute utilities

By understanding the evaluator's preference for the selected attributes, it is possible to derive utility functions for quantifiable attributes over the considered attribute measuring scales. Having such utility functions makes it possible to measure the single-attribute utilities for each alternative, based on where it fits on the utility curve. For non-quantifiable attributes, the evaluator's direct utility assessment can be used.

2.2.5-Assigning attribute weights

For each alternative, the aggregate utility value is determined by adding the product of the multiplication of each single-attribute utility with its assigned weight. Attribute weights reflect the contribution of each attribute in the overall utility index. Attribute weights are not just measures of importance; they also reflect the range of variation along the attribute measuring scale. If the range of variation is very small, the attribute weight diminishes and may exclude the attribute from the model. For example, if all of the alternatives' costs are very close, the weight assigned to the "cost" attribute is very small if it fails to clearly distinguish among alternatives.

2.2.6-Checking attribute utility independence

To calculate the single-attribute utility functions, certain forms of utility independence should exist among attributes. Independence

assumptions require that the decision maker's preference for attribute levels shows uniformity as changes are made to other attributes (Pitz and Killip, 1984).

The condition of the utility independence must hold to separately calculate the utility functions for each attribute. In other words, the utility function for each single attribute must be independent of the other attributes' utilities.

The utility independence condition can be explained by the following example. For any two attributes, Y and Z, consider y_1 , y_2 , z_1 , and z_2 to be different levels of Y and Z. If z_1 is preferred to z_2 when Y is at the y_1 level, then z_1 must be preferred to z_2 when Y is at the y_2 level, indicating that the preference among levels of the first attribute, Y, is unrelated to the level of the second attribute, Z. Thus it is said that attribute Z is independent of attribute Y.

As Figure 2 shows, Keeney and Raiffa (1976) analogized the concept of attribute utility independence as a hypothetical lottery. Understanding the analogy between these hypothetical lotteries and the concept of utility forms the basis for obtaining single-attribute utility functions. For the two-attribute case shown in Figure 2, the certainty equivalent \hat{y} for a 50-50 gamble yielding attribute values y_1 , and y_2 given that attribute Z is held fixed at z_0 (lottery 1), does not shift if z is held fixed at some other level z_1 (lottery 2).

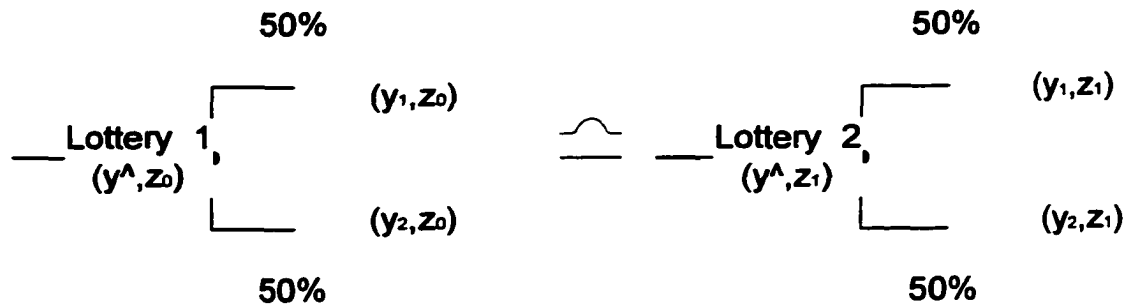

Figure 2. The analogy between utility independence and hypothetical lotteries

This means that the certainty equivalent \hat{y} depends solely on the y_1 and y_2 values and not on the fixed value of z . In other words, the preference between the two lotteries involving different amounts of attribute Y does not depend on the fixed level of attribute Z , implying that Y is utility independent of Z , because the conditional utility for lotteries on Y given Z does not depend on a particular level of Z (Winterfeldt and Ward, 1986). In this case, the utility function for Y can be considered without referring to any particular z .

If attribute utilities are found to be dependent, the assessment of utilities becomes very difficult. However, the problem can be solved by redefining attributes to be preferentially independent, combining one or more of them, or eliminating the attribute from the analysis (Pitz and Killip, 1984).

2.2.7-Utility aggregation rules

The model structure differs according to the problem analyzed. In theory, it is possible to use several methods for combining single-attribute utilities with their corresponding weights in the model (Winterfeldt and Ward, 1986). The following paragraphs discuss the additive and multiplicative aggregation rules.

2.2.7.1-Additive rule

The additive rule is the simplest aggregation rule, where single-attribute utilities are multiplied with the attribute weights and summed. The additive rule can also be analogized using the hypothetical lotteries shown in Figure 3. Lottery 1 has an equal chance of getting either the lowest level of each attribute (y_0, z_0) or normal levels of y , and z . In lottery 2, there is always a normal level of one attribute and the lowest level of the other, for example, (y, z_0) or (y_0, z). The indifference between lottery #1 and lottery #2 analogize the additive rule.

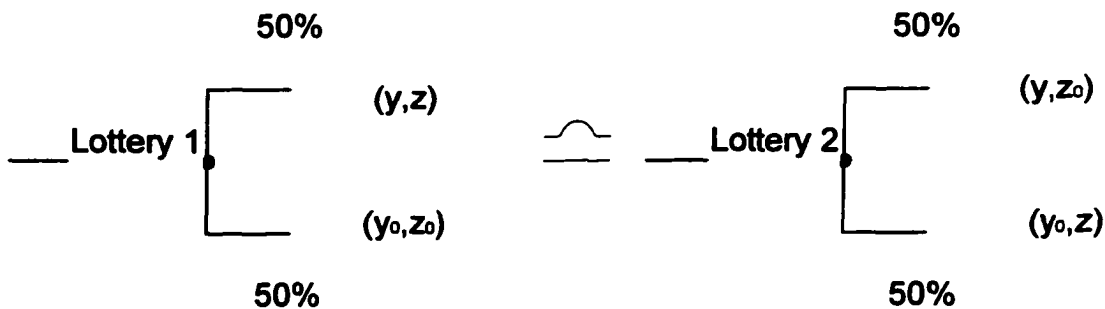

Figure 3. The additive rule and the concept of lottery indifference

To mathematically prove this point, $U (y_0, z_0)$ is normalized by setting the aggregate utility of the lowest attribute levels to equal 0.

$$\text{i.e., } U (y_0, z_0) = 0.$$

Taking the expected utility for each lottery,

$$1/2 U (y, z) + 1/2 U (y_0, z_0) = 1/2 U (y, z_0) + 1/2 U (y_0, z)$$

And substituting for $U (y_0, z_0) = 0$,

$$U (y, z) = U (y, z_0) + U (y_0, z) \quad \text{Equation 2}$$

By defining $U (y, z_0) = k_y U_y (y)$, and $U (y_0, z) = k_z U_z (z)$, where k_y and k_z are the attribute weights; and substituting in Equation 2, one obtains the following additive rule:

$$U (y, z) = K_y U_y (y) + K_z U_z (z) \quad \text{Equation 3}$$

2.2.7.2-Multiplicative rule

The previous additive rule has the disadvantage that it does not allow for interactions among the attributes. Relationships among attributes can be described as “supplementary” or “complementary.” For the two-attribute case, complementary relationship requires that both attributes be at satisfactory levels at the same time. The supplementary relationship implies that having one attribute at a satisfactory level substitutes for a less satisfactory level of the other attribute.

For example, the relationship between technology performance and its resistance in a harsh environment can be described as

complementary. High technology performance is not appreciated if the technology cannot withstand the working conditions. Technology resistance to the working environment is also not beneficial if the technology does not meet the expected performance standards. In this case, the multiplicative rule can work as a discounting factor for both performance and resistance, if one of them does not perform well.

On the other hand, the relationship between technology “cost” and “risk” is an example of a supplementary relationship, which implies that it might be acceptable to get a risky technology for a cheap price or presumably risk-free technology for an expensive price. In this case, the satisfactory level of one attribute compensates for the less satisfactory level of the other.

Keeney and Raiffa (1976) developed a general form that considers different interactions among attributes. If attributes are mutually utility independent, then their aggregate utility function can be expressed as follows:

$$U(x) = \sum_i w_i u_i(x_i) + \sum_{i < j} k w_i w_j u_i(x_i) u_j(x_j) + \sum_{i < j < m} k^2 w_i w_j w_m u_i(x_i) u_j(x_j) u_m(x_m) + \dots + \dots + k^{n-1} \prod_{i=1}^n w_i u_i(x_i) \quad \text{Equation 4}$$

In the preceding equation, the utility for each attribute U_i, U_j, \dots, U_m is multiplied by its weight w_i, w_j, \dots, w_m , as well as by an additional

interaction parameter (k) or by its power. All attribute interactions in the model are based on k . k is interpreted as a parameter that determines the manner in which the single-attribute utilities interact with each other. All of the preceding terms are added together. As Equation 4 shows, the power of the interaction parameter k increases as the number of interacting terms increases (Winterfeldt, 1986). As the absolute value of k increases, the attribute relationships involve more interactions. When there are no interactions among attributes, the interaction factor k reduces to zero, and the utility aggregation relationship turns out to be an additive relationship.

If $k \neq 0$, then by multiplying Equation 4 by k , adding 1, and factoring, one obtains the multiplicative utility function derived, in its short form, by Keeney and Raiffa (1976) as follows:

$$kU(x) + 1 = \prod_{i=1}^n [kw_i u_i(x_i) + 1] \quad \text{Equation 5}$$

then,

$$U(x) = [\prod_{i=1}^n [kw_i u_i(x_i) + 1] - 1] / k \quad \text{Equation 6}$$

Where the symbol \prod indicates that the terms inside the brackets are multiplied together. Within the brackets, w_i and u_i represent single-attribute utilities and weights, respectively. As Keeney and Raiffa (1976)

proved, k is the interaction factor that is defined by the following relation:

$$k = \prod_{i=1}^n [1 + kw_i] - 1 \quad \text{Equation 7}$$

So, Equation 6 can be written as follows:

$$U(x) = \left[\prod_{i=1}^n [kw_i u_i(x_i) + 1] - 1 \right] / \left[\prod_{i=1}^n [1 + kw_i] - 1 \right] \quad \text{Equation 8}$$

2.2.7.2.1-Relation between the hypothetical lottery concept and attribute interactions

Keeney and Raiffa (1976) interpreted the attribute interactions using the hypothetical lotteries in Figure 4. It is assumed that a more risky lottery (lottery 2) is such that it is possible to get the highest level of both Y and Z (Y best, Z best) or the lowest level of each (Y worst, Z worst). On the other hand, for the less risky lottery (lottery 1), it is always the highest level of one attribute and the lowest level of the other, i.e., (Y best, Z worst), OR (Y worst, Z best).

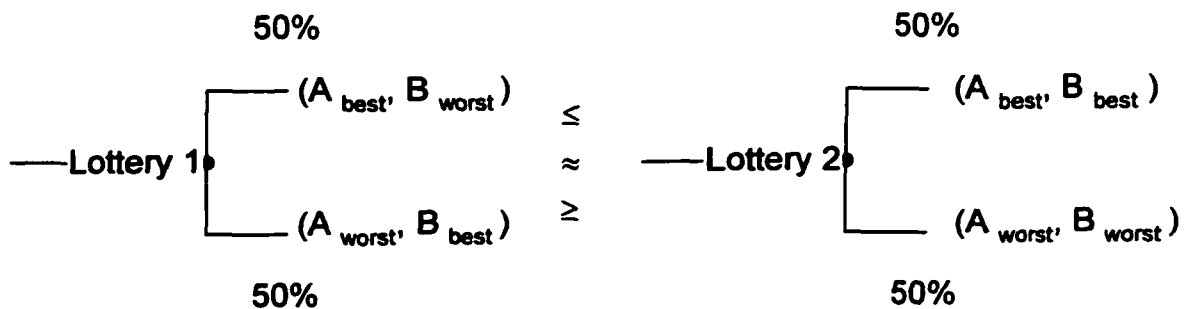

Figure 4. Interpreting the attribute interactions using hypothetical lotteries

To better explain how the hypothetical lotteries can represent the supplementary and complementary relationships among attributes, lottery #1 and lottery 2 are depicted on a Y-Z axis as in Figure 5. If lottery 2 is preferred to lottery 1, the decision maker apparently wants to increase the worst attribute to complement the increase in the other attribute. Otherwise, the full benefit of the increase of the good attribute is not exploited, which implies a complementary relationship such as the relationship between technology, reliability, and performance.

On the contrary, preferring lottery 1 in Figure 5 implies that the preference of doing well occurs in at least one attribute, meaning that achieving a satisfactory level of one attribute makes achieving a satisfactory level in the second attribute of low importance. This would analogize a supplementary relationship between attributes Y and Z in Figure 5.

When the two lotteries are equally attractive to the decision maker, the implication is that the two attributes Y and Z are not interacting. In other words, the decision maker is not willing to tradeoff among attribute levels. Whether the lotteries are perceived as equivalent depends on the decision maker's preference toward the considered attributes.

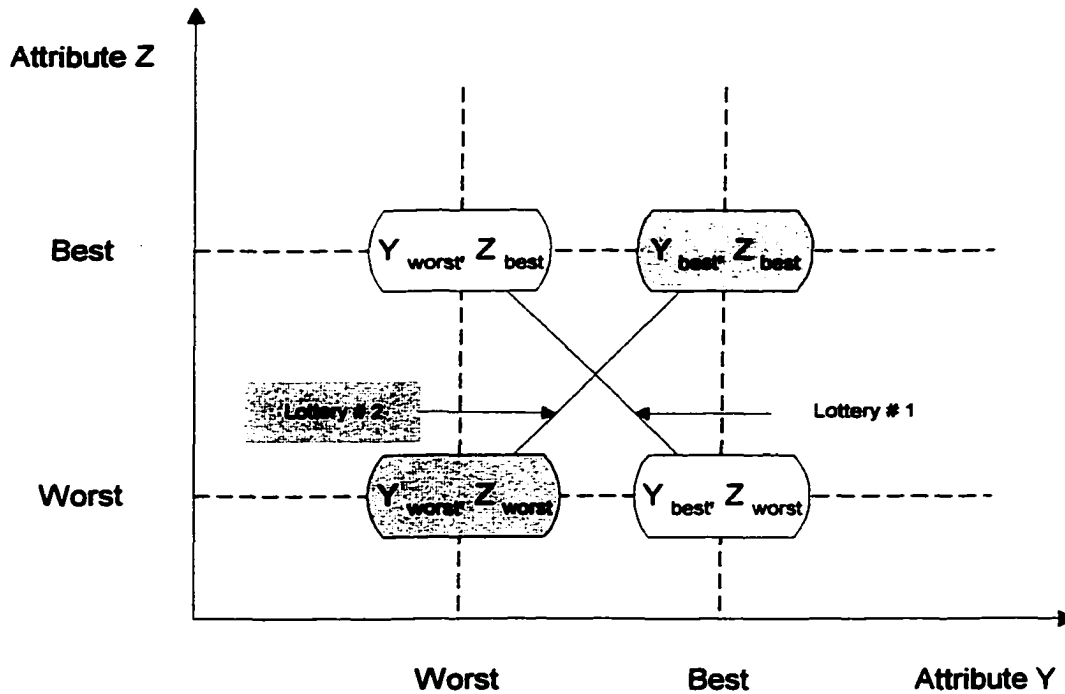

Figure 5. Using hypothetical lotteries on x-y axis to interpret the interaction between two utility attributes

In other words, the decision maker's preference for these hypothetical lotteries reflects the interaction between attributes. The following section explains how the hypothetical lotteries can be used to calculate the interaction parameter k .

2.2.7.2.2-Calculation of the interaction parameter k

The three hypothetical options (A, B, and C) in Figure 6 are derived from lotteries #1 and #2 in Figure 5. Options A and C are fixed and represent two extremes in which one attribute is at the best level and the other is at the worst level. Option B represents a gamble in

which it is possible to get both attributes either in their best or worst levels together.

The purpose of this approach is to figure out the decision maker's preference about pushing one of the attributes to its best level compared to pushing the other one to its best level. By this, the decision maker can implicitly assign interaction among attributes.

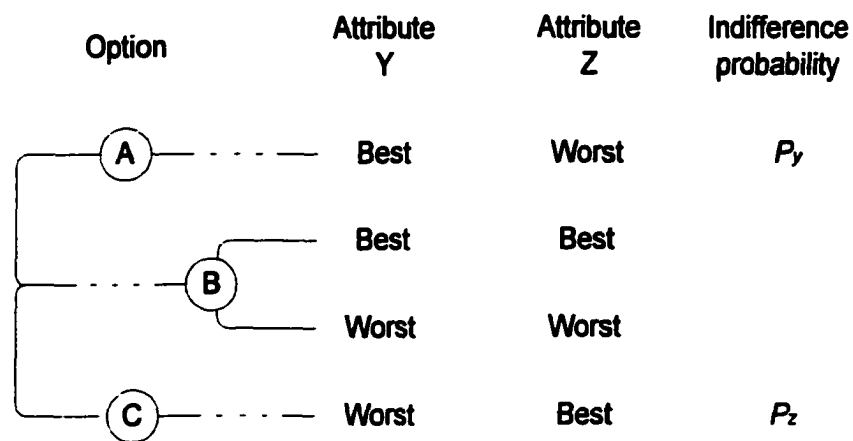

Figure 6. Calculations of indifference probabilities

This approach, developed by Keeney and Raiffa (1976), requires obtaining the decision maker's indifference probabilities (p_y , and p_z) between option A and lottery B, as well as between option C and lottery B. For example, the indifference probability, p_y , in Figure 6 measures the willingness of the decision maker to risk losing everything on attribute Y (in option A) for a chance to gain everything in terms of

attribute Z (in lottery B). To obtain p_z , the same process is repeated for option C and lottery B .

Since the indifference probabilities (p_y, p_z) reflect the tradeoffs among attributes, the method described here explicit the issue of risk in exchanging levels of one attribute for levels of another (Pitz and Killip, 1986). Consequently, p_y and p_z represent the relative weight of a change in one attribute from its worst to its best level on overall utility (Winterfeldt and Ward, 1986). If the decision maker views this change as unimportant, he will assign a high indifference probability, because the gamble is not as attractive as the fixed option.

As Keeney and Raiffa (1976) prove, the indifference probabilities can be converted into interaction weights depending on the sum of p_y and p_z . If the sum is equal or close to 1.0 (0.9~1.1), there is no interaction between Y and Z , and the additive integration rule holds (Pitz and Killip, 1984). On the other hand, if the sum of p_y and p_z does not add up to 1.0, then the parameter k can be calculated as follows:

$$k = (1 - p_y - p_z) / p_y p_z \quad \text{Equation 9}$$

Note that since p_y and p_z are such that $0 \leq p_i \leq 1$, Equation 9 limits k to $-1 \leq k \leq \infty$. For example, if $p_y = p_z = 0$, $k = \infty$; and if $p_y = p_z = 1$, $k = -1$. It is also clear that when $p_y + p_z = 1$, $k = 0$ and the additive rule applies.

2.2.8-The aggregate utility function

Once parameter k is determined, Equation 8 can be used to calculate the aggregate utilities for evaluated options. To simplify the form of this equation, the scaling constant k can be combined with w_i as follows:

$$\text{By setting } w_i^* = k w_i \quad \text{Equation 10}$$

And substituting for w_i^* in Equation 8, the aggregate utility function can be expressed as follows:

$$U(x) = \left[\prod_{i=1}^n [1 + w_i^* u_i(x_i)] - 1 \right] / \left[\prod_{i=1}^n [1 + w_i^*] - 1 \right] \quad \text{Equation 11}$$

For the two-attribute case, the interaction weights for Y and Z can be expressed by substituting for Equation 9 into Equation 10 as follows:

$$w_y^* = (1 - p_y - p_z) / p_z \quad \text{Equation 12}$$

$$w_z^* = (1 - p_y - p_z) / p_y \quad \text{Equation 13}$$

Using Equations 11, 12, and 13 makes it much easier to calculate the aggregate utilities for all evaluated options. Note that each attribute in Equation 11 causes the term in which it is included to deviate from 1.0. On the other hand, if either u_i or w_i^* is equal to zero, the term equals to 1.0 so it does not affect the product of other terms.

It should be noted that the interaction weights can be larger than 1.0 or negative. The negative weights can occur when the sum of the indifference probabilities exceeds 1.0, meaning that the risky option (B

in Figure 6) is seen as unattractive compared to the fixed options. This implies a negative interaction or supplementary relationship among attributes. On the other hand, when the risky option B is seen to be more attractive than fixed options, the sum of the indifference probabilities will be less than 1.0 and the interaction weights in Equations 12 and 13 will become large and positive.

This unusual form of interaction weights makes sense because w^*_i determines both in what direction and by how much the term $(1 + w^*_i u_i)$ in Equation 11 deviates from 1.0. If all of the w^*_i are positive and large, the aggregate utility will be large only if all the single-attribute utilities are large. One small utility will obviously reduce the aggregate utility. For complementary attributes, the aggregate utility will be high only if all single attribute utilities are at satisfactory levels. On the other hand, if all w^*_i are negative, any one single attribute utility will increase the aggregate utility. This is desirable when the relationship among attributes is supplementary.

The next chapter explains how the previous theory was used to construct a model that evaluates two types of data capture technologies.

CHAPTER 3. DEVELOPING A MODEL THAT SELECTS AMONG DIFFERENT BAR CODE AND RFID SYSTEMS IN CONSTRUCTION MATERIAL TESTING LABS

During the search for construction organizations having data capture selection issues, some materials testing laboratories expressed their interest in applying the multi-attribute utility model (MAUM). One government lab and five private labs in Iowa participated in this study (see Table 1).

Table 1. Material testing labs participating in the study

Lab Name	Type	Location
○ Iowa Department Of Transportation (IDOT) material testing laboratory.	Government	Ames
○ Wyle laboratories Inc.	Private	Waterloo
○ Certified Testing Services Inc.	Private	Sioux City
○ Patzing Testing Laboratories	Private	Des Moines
○ American Testing and Engineering	Private	Quad City
○ Robert Nady Test Lab	Private	Des Moines

In this study, the multi-attribute utility theory (MAUT) is used to develop a model that helps decision makers at these labs assess different bar code and radio frequency identification (RFID) systems for identifying and recording sample test results. Bar code and RFID technologies are selected because they are the most common data capture technologies today.

The model development starts by defining the selection problem in construction materials testing labs and identifying different bar code and RFID systems alternatives. Determining evaluation objectives and defining attributes serving those objectives, attribute utility functions, and attribute weights are necessary to form the model structure. Objective utilities are calculated and combined to obtain the aggregate utilities for the evaluated bar code and RFID systems.

It must be noted that the words “technology” or “Data capture technology” are used interchangeably and refer to either a bar code or RFID technology. On the other hand, the words “system” or “option” mean a specific brand or certain configuration of either a bar code or RFID technology.

The study determines

- To what extent the MAUM can enhance the data capture systems selection decision.
- The technical, economic, and aggregate utilities and merit ranking of data capture systems in this study.
- The value-related attributes that best describe portable data terminals (PDT).
- Whether there are technology preference differences between government and private lab needs.

- Whether there are technology preference differences between information technology professionals (ITP) and technicians in material testing labs.
- The most sensitive attributes that have the strongest impact on technology evaluation.

Based on the MAUT described in Chapter 2, the methodology followed in this research is explained in detail in the next few sections.

3.1- Defining Sample Identification and Data Recording Problems in Construction Material Testing Labs

3.1.1-Type of work in construction materials testing labs

The objective of the material testing labs is to determine whether the quality of construction materials, such as aggregate, concrete, and asphalt, are in reasonably close conformity with approved plans and specifications. Materials are tested to the correct standards, and reports for each construction project should be produced on time. The volume of work is huge for some of these labs. For example, in 1999, at the IDOT lab, the largest lab in this study, 5,827 tests were performed on aggregates; 9,639 tests on asphalt materials; 8,952 tests on concrete; and 7,357 tests on soils (www.state.ia.us/dot/specifications/April2001). The other participating labs vary but are generally smaller in size.

3.1.2-Current data recording procedure

To gain insight into the sample identification and test result recording process in construction material labs, the current processes in the participating labs were carefully investigated.

The Laboratory Management Information system (LIMS) is almost identical in all labs. Each sample is assigned a number on a paper tag or label for identification. The LIMS requires maintaining records of all information resulting from monitoring test activities and results. This includes

- Sample number, description, and supplier name
- The date, exact place, and time of sampling
- The date tests were performed
- The technician who performed the test
- The analytical techniques used in the test
- The test results

This information is recorded manually on a printed form by the lab technician. The form is sent later to the lab secretary who enters the test data into the computer. Based on the technician's recommendations, compliance/noncompliance reports are issued. Figure 7 depicts the current test data recording process in the IDOT lab.

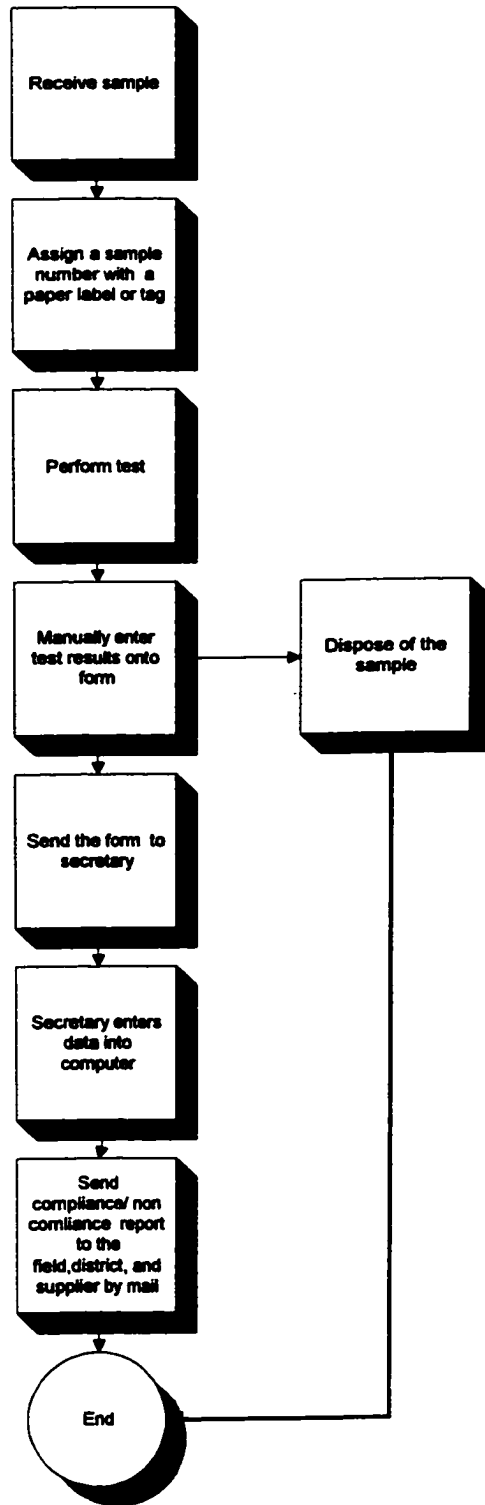

Figure 7. Current test data recording process at IDOT laboratory.

3.1.3-Data recording process inefficiency

As Figure 7 shows, the data recording process starts by identifying the sample. Lab technicians have to attach paper tags to each sample. Currently paper tags with a handwritten sample identification number are either stuck or attached to the sample using a wire. Technicians have to copy this number, as well as test data and results on the test data sheet. Because data is manually recorded on forms before entry to the host computer, issues associated with interpreting handwriting; transposing numbers, which results in many errors; and a slow process are not resolved. In the IDOT lab, two secretaries spend approximately 15% to 20% of their time in data entry. According to John Hinrichsen at the IDOT, although the main objective for recording test data is to have up-to-date information about the test conditions, a test might be performed in only a few minutes; however, the recording process might be completed 3 days later. Private labs reported similar problems especially during the peak construction season.

With the continuous growth of laboratory responsibilities, it is increasingly difficult to maintain accurate and up-to-date records of test results. The time taken to record test results and update the system needs to be dramatically reduced. Overall, data need to be managed more efficiently.

3.1.4-Identifying opportunity for improvement

Unlike the current paper-based identification and recording system, using a data capture technology allows lab technicians to identify samples and record test data electronically only once at the point of test. The test data can then be downloaded to the host system, eliminating all of the paperwork. This should help reduce process time and improve data quality.

3.1.5-An overview of bar code and RFID technologies

Bar code and RFID technologies serve the main purpose of automating data entry process without using a computer keyboard. These technologies eliminate two error-prone and time-consuming activities: manual data collection and data entry (www.aimglobal.org/technologies, 2001).

Bar code and RFID systems are similar because each of them uses a reader and coded data carrier attached to the object. However, bar code systems use optical signals to transfer data between the bar code reader and label, while, RFID systems use radio frequency (RF) signals to transfer data between the reader and the RFID tag. The following paragraphs briefly summarize the two technologies.

3.1.5.1-Bar code system components

Bar code system components basically consist of a reader, bar code labels, and printers. Many bar code symbologies are used in a

variety of applications. Each symbology represents the rules for character encodation, error checking, printing and decoding requirements, and many other features. Today, the most popular ones are the Universal Product Code (UPC), the European Article Numbering (EAN), Code 39, Interleaved 2 of 5 Code, and Code 128...etc. Code 39 is being used in construction and most construction-related applications (Blakey, 1990).

In general, bar codes can be classified into three main categories: linear (one-dimensional), stacked, and matrix bar codes (two-dimensional). Compared to one-dimensional bar code, stacked and matrix bar codes have more data capacity and resist damage. For more information about bar code technology, refer to Appendix B.

3.1.5.2-RFID system components

Radio frequency identification systems typically consist of four basic components:

- (1) Tag, or transponder, as a data carrier
- (2) Antenna to transfer the RF signal from the reader to the tag and vice versa
- (3) Scanner to generate the RF signal
- (4) Reader to convert the scanner's analog signal into a digital format to pass the data to the host computer

In some industrial applications where equipment may be permanently fixed, each of these components is a separate item. In other applications where portability is required, some of the components may be combined into one hand-held configuration.

Data can be encoded on the tag in such a way that only authorized users can read or write data. The amount of data stored on a tag depends on the application. In general, tags may contain the following information:

- Identification number, in which a numeric or alphanumeric string is stored on the tag to identify or track items or as an access key to data stored in a computer.
- Portable data files containing all information pertinent to the item.

For more information about RFID technology, refer to Appendix C.

3.1.6-The problem of selecting the data capture system

Selection of data capture technologies is challenging. The data collection technology market is saturated with devices of different capabilities, making device selection a challenge (Cohen, 1994). The reason for difficulty in selecting a particular technology is that no one technology is dominant in all its attributes. Decision makers cannot maximize all these attributes simultaneously.

Labs participating in this study have been considering updating their data recording process by introducing one of the data capture systems. However, there was no formal method for evaluating these systems. For example, in the IDOT lab, an ad-hoc committee, composed of lab technicians and ITPs decided to use one of the bar code or RFID systems. Some committee members had contacted data capture technology suppliers and found it was not easy to select the best system for lab operations. This left the IDOT committee undecided, and the project is currently postponed.

The rest of the labs in this study are also planning to adopt one of the data capture technologies sometime in the future. These labs reported similar difficulties to those encountered by the IDOT committee in terms of technology selection. Therefore, the labs participating in this study are still preparing to select a data capture technology.

3.2- Identifying and Screening Data Capture Technology Alternatives

As the labs participating in this study considered data capture technologies, a thorough analysis of possible data capture systems was performed. The search involved an extensive literature review, reviewing manufacturers and associations' websites, exchanging e-mail with experts, and interviewing lab technicians and ITPs. For more information about bar code and RFID technologies, refer to Appendixes

B and C. The preliminary search resulted in identifying many systems on the market. For example, AIM (the global trade association for automatic identification and data collection) has listed more than 500 bar code systems and 68 RFID systems in its website. Some other systems are described in manufacturers' websites and catalogs. Figure 8 describes the data capture system screening process. In the preliminary search, fixed data capture readers are excluded because they best fit unattended operations. In testing labs, samples are located all over the labs. Therefore, portable systems are considered for further screening, because they enable lab technicians to record data while performing the test. As a result of the search, either a bar code or RFID reader incorporated with a PDT was chosen as the best solution. New PDT products contain built-in readers that are an integral part of the PDT unit. This "one-hand solution" combines both data collection and auto identification systems. Figure 9 shows some examples of the PDTs evaluated in this study.

For materials testing labs, PDTs have the advantage of recording test data by taking the PDT to the data source rather than bringing the data source to the computer as is the case when bar code or RFID readers are separated from PCs.

Considering that the lab technician has to work very closely with the sample, the interrogation range does not need to be very long.

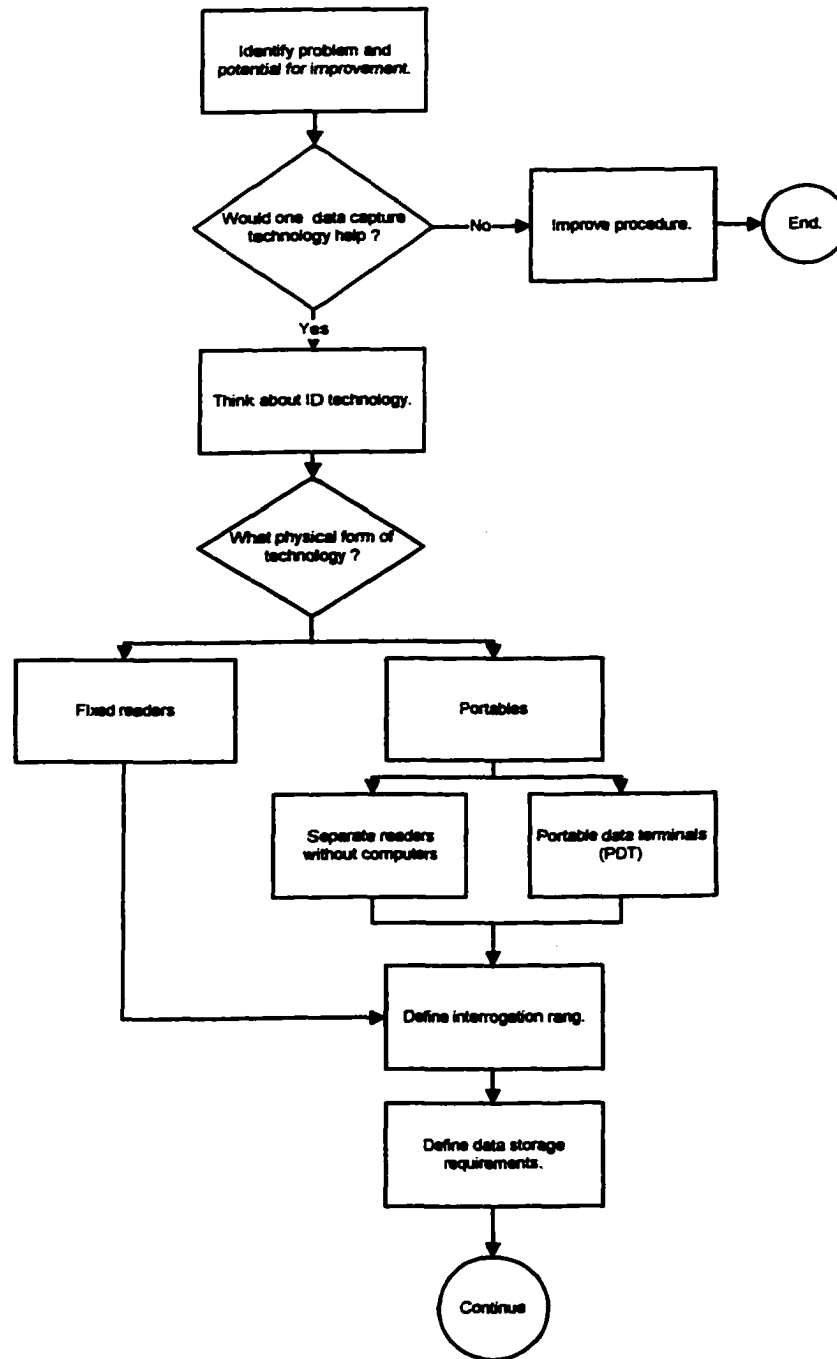

Figure 8. Process of screening different data capture systems

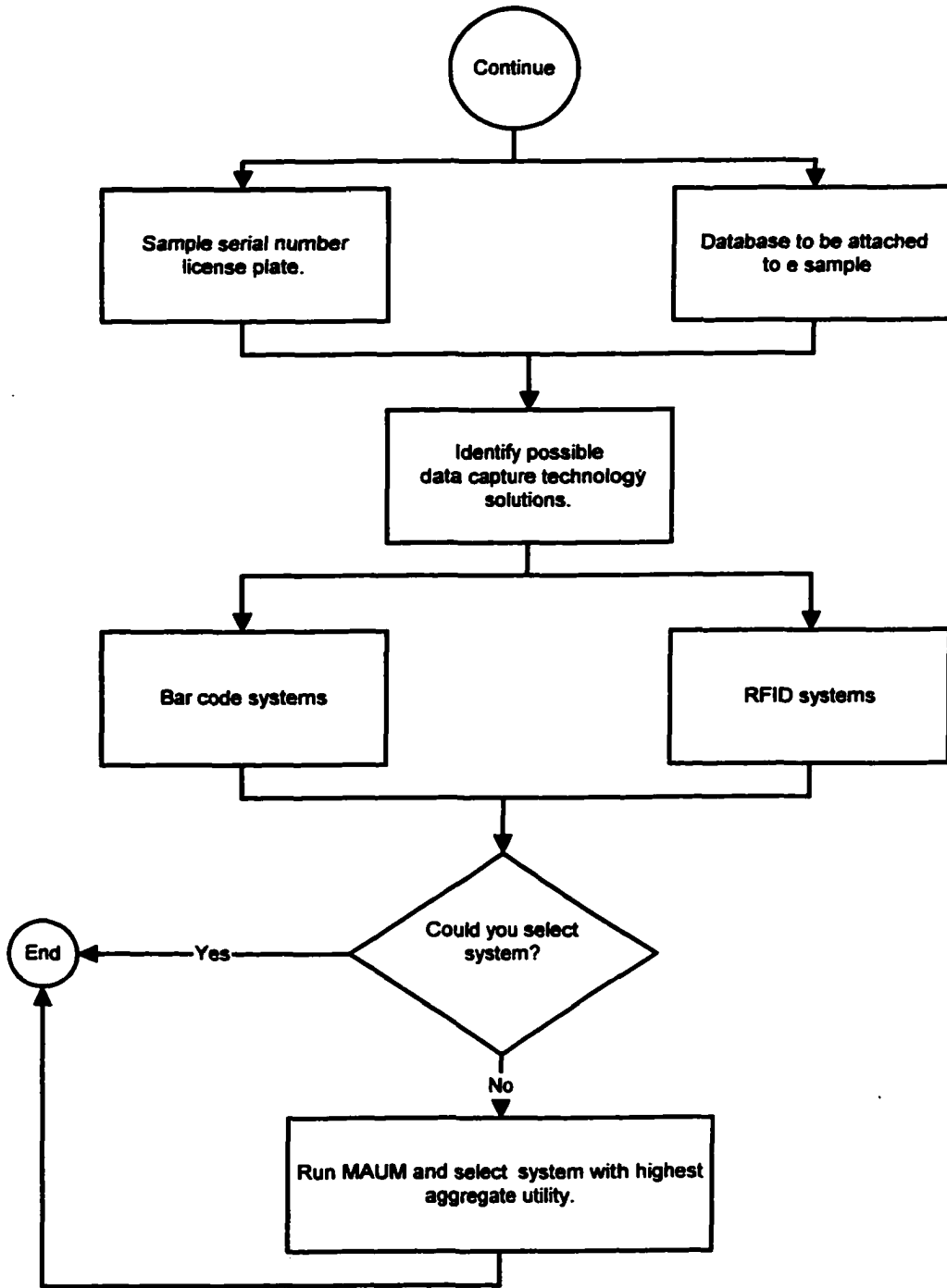

Figure 8. Continued.



Figure 9. Some bar code and RFID data collectors
From left: Memor2000-RFID, Dolphin7400, and Intermec 5020

There is no need for a large storage capacity, because no portable data file accompanies the sample. A sample will only be identified by an identification number that acts as a data key or address for a particular record in a data file. Therefore, two-dimensional bar code and high-storage RFID systems are excluded. Considering these initial configurations, the preliminary screening resulted in selecting ten data capture systems (5 bar code and 5 RFID systems) for MAUM evaluation. All systems were PDTs with either a bar code or RFID reader.

3.3- Systems Evaluation Objectives

Because the MAUM requires developing selection criteria for evaluating technology, three main objectives were identified: (1) technical merit, (2) economic merit, and (3) low-risk merit. Systems' utilities were calculated based on the degree to which these objectives

were achieved. The single-attribute utility for all of these objectives was be combined in the form of an aggregate utility index for each system.

3.4- Determining Attributes

3.4.1-Initial attribute list

The process of defining evaluation objectives and attributes was an iterative one. All attributes initially thought to achieve the objectives are listed in Table 2. Shaded attributes in Table 2 were later excluded throughout the model development stages. The next section explains the reasons for excluding these attributes.

3.4.2-Process of excluding some attributes from the model

The problem with too many attributes is that they make the analysis cumbersome. Thompson and Newman (1982) recommended that no more than 15 to 20 attributes be analyzed. To reflect the differences among systems, only important attributes were selected. Shaded attributes in Table 1 are either excluded from the model or combined with other attributes. This does not necessarily mean that the excluded attributes are not important, but that some important attributes might not contribute to the analysis. There was at least one reason for excluding the shaded attributes. For example, the *reading speeds* for all systems are, in general, very close. Reading speeds only differ in milliseconds. Trying to obtain reading speeds from

manufacturer catalogs might not be very reliable. Therefore, the “reading speed” attribute was excluded from the model.

The technology’s *direction of reading* refers to how the user can approach the identified object from different directions (front, back, above, and under). For example, bar code technology is a uni-directional technology compared to RFID, which is omni directional. This feature could be overlooked in the analysis because lab technicians always approach the samples from the front.

Data storage capacity refers to the maximum recorded amount of data on a label. On the other hand, *data density* refers to the maximum amount of data that can be encoded in a given area of the data carrier. Because it was decided that the data carrier would only include the sample identification number, both *data storage capacity* and *data density* were not major factors that distinguished between bar code and RFID systems for material labs use. All systems can accommodate the sample identification number.

First Read Rate (FRR) is the probability of a successful read of the data at first trial, and *Substitution Error Rate (SER)* is the probability of misreading an encoded character and replacing it with a wrong one.

All system manufacturers claim their products have high *FRR* and low *SER* (one over several millions), which make it almost the same for all systems.

For the physical configurations, all PDT systems in this study have *screen contrast control* and *backlighting* for poor lighting conditions. PDT *screen resolution* is very close for all systems.

The *communication interface* connects the data capture system to a host computer terminal. All systems have RS-232 serial communications ports. Some of the systems have other interfaces such as RS-422 in addition to RS-232; however, RS-232 works well as participating lab staff reported.

Information technology professionals and technicians in the labs reviewed the systems and reported that all PDTs considered are *compatible with their existing systems*.

Because they are non-quantifiable attributes, *data integrity* of a technology as well as the *possibility of being readable by people* were later incorporated under technology security attribute.

It is also hard to judge "*vendor reliability*" before purchasing. PDT vendors are not providing enough information about after-sale support.

There is no need to consider *training cost*, because all systems are easy to use. Jaselskis and Elmisalami (2000) reported that it took only 15 minutes to train Bechtel field workers on using one of the RFID systems.

As for quantifying the benefits *for each system*, all systems serve the same purpose of identifying samples to record test results but with different quality. Because it is impossible to perform *pilot tests* for all systems to measure the benefits, the quality of service as reflected in system attributes was considered an indirect measure of system benefits.

A higher *expected number of technology users* is desirable, because the more the better. For the systems considered, there was no indication that a system configuration affects the number of users.

All systems are *user friendly*. It is difficult to predict the *user satisfaction* with each system, but it is assumed to be the same or very close for all systems. There should not be any *difficulty in system implementation*. All systems are *safe* and should not have any negative *impact on user's morale*.

Technology standards are not yet available for RFID systems; therefore, it is included under the low-risk objective as explained later.

Table 3 lists the attributes that were elicited to be included in the model. These attributes are discussed in the following section. The table also displays the structure of the three objectives defined in Section 3.3 in this chapter, including technical merit, economic merit, and risk-less merit. The first objective extends down to two lower level objectives of technology “capability” and “reliability.” The technology capability

objective, for example, leads to the definition of thirteen attributes. The technology reliability objective generated five more attributes. The economic merit objective involves considering two cost attributes. As mentioned previously, benefits are reflected in other system attributes, because they are an indirect measure of benefits. The last objective, “low-risk merit” is subjectively defined to reflect the evaluator’s feeling about the certainty/uncertainty associated with each technology (bar code or RIFD).

3.4.3-Explanation of model attributes

The objectives/attributes structure listed in Table 3 can serve as a basis for evaluating the selected data capture systems.

This section explains the model attributes. Capability objectives are represented by 13 attributes such as the *Maximum distance between data carrier and reader*, which determines the maximum distance from which a data reader can approach the information in the data carrier.

Some RFID systems have writing ability, which makes it possible to update the information by writing back to the tag many times. All bar code and some RIFD systems are read-only technology. Maximum throughput defines the amount of data to be transmitted in a given amount of time, usually seconds. It indicates the system speed.

Table 3. Objectives and attribute hierarchy as included in the final model

Objectives and attribute hierarchy	
TECHNICAL MERIT	
System capability	
	Maximum distance between data carrier and reader
	Technology writing ability
	Maximum throughput
	CPU speed
	Technology operating system
	Base RAM
	Maximum RAM
	Hard drive capacity
	Screen dimension
	Communication interface
	No. of keyboard keys
	Weight including battery
	Battery life
	Built in wireless capability
System reliability	
	Technology security
	Data carrier environmental resistance
	PDT rugged characteristics
	Technology's need for a line-of-sight to read
	Possible adverse effect (anti collision, metal effect...)
ECONOMIC MERIT	
System cost	
	Initial investment
	Operating cost
LOW-RISK MERIT	
	Technology certainty

PDT *processor speed* affects the data processing capability. Although these types of data collection systems are not required to handle large amount of data at one time, a strong processor is needed for searching large data files.

For many people, working with operating *systems* such as *Windows* is preferable to *DOS*. Therefore, the operating system is an important factor to be considered.

Memory capacity is a major consideration in selecting a data collection system. Random access memory (RAM) is the place in a computer where the operating system, application programs, and data in current use are kept so that they can be quickly reached by the computer's processor.

Some PDTs are designed to facilitate adding additional RAM. The *Maximum RAM* that can be added in the future extends the computer's capability. Having more RAM in a computer reduces the number of times that the processor has to read data from the hard disk, an operation that takes much longer than reading data from RAM.

Not all PDTs have *hard drives*. Some use PC cards, others store data on RAM. As in all computers, more storage capacity is always preferred.

PDT *screen size*, measured by the number of screen lines, is an important attribute, because the PDT user has to find the input field on

the screen as quickly as possible. Larger screens are not always best; they might be more expensive and weigh more than the smaller ones.

PDT *"number of keyboards"* can vary widely. Some keyboard layouts include numeric only or full alphanumeric. The alphanumeric character set contains letters, digits, and usually other characters such as punctuation marks. Depending on the intended use, the need for all of the sets differ. Some keys might not be required for all data collection applications.

PDT *weight* is also important in the lab environment because users may have to carry the unit for a considerable amount of time.

PDTs are battery driven. Most PDTs are supplied with rechargeable nickel cadmium (Ni-Cads) cells. Other PDTs use disposable alkaline batteries. Very few are powered by both types that is have a backup source of power. *Battery life* is an important factor in determining how long batteries operate before they need a recharge.

PDT systems supplied with *RF wireless capability* can update the host computer system instantaneously as data readings occur. Not all systems have this capability.

For *security* purposes, some technologies are less secure than others. For example, it is possible to copy a bar code label and read it. On the other hand, it is almost impossible to copy an RFID label.

Data carrier environmental resistance determines to what extent the data label survives in a harsh environment. For some users, RFID tags seem to be more robust than bar code labels and can resist chemicals and high temperatures.

Unlike other non-portable computers, PDT is subject to severe work conditions. Some PDTs have *rugged characteristics*. These PDTs have passed durability tests up to military standards; they can withstand falls, vibration, chemicals, dust, and rain.

Some technologies, like bar code systems, always require a *line-of-sight* between the reader and data carrier. On the other hand, low-and-medium frequency RFID systems do not require a line-of-sight, which makes them more suitable for some applications where tags might be hidden behind the object and cannot be easily seen.

The possibility of facing *some adverse events* from the surrounding environment might restrict the use of some data capture technologies, such as RFID systems. RFID systems do not work very well when tags are attached to metal surfaces. This problem might not be encountered by bar code systems. It is also possible that RFID systems face some sort of reading collision when many tags are read in close proximity.

Because *technology cost* is a very important consideration, the *Initial investment* includes the PDT's purchase cost, as well as the printers' cost for bar code systems.

Operating cost should also be considered. Some RFID systems are maintenance-free systems. Theoretically, tags can be reused an unlimited number of times. On the other hand, bar code systems require consumables such as ribbon, labels, and printer maintenance.

Concerning the *risk factor* resulting from using new technology, all risk factors are included under the *low risk merit* objective as mentioned before. Each evaluator evaluates technologies based on how certain/uncertain he is about the technology.

Sources of uncertainty are numerous. Some sources could be related to the model structure, such as the possibility that the selected attributes are not good indicators for the selection problem, or to low user knowledge of technology. Some concerns are related to uncertainty about the technologies. For example, there is a lack of standardization in the RFID industry. RFID systems are closed systems, meaning that one manufacturer's reader might not read tags manufactured by another. On the other hand, bar code systems have been on the market for a while and are trusted more, making them preferred by adverse risk decision makers.

3.5-Defining Attribute Measuring Scales

When the model objectives and attributes were satisfactorily defined, the quantification process started by defining system attribute measures. Table 4 lists the attribute measures for the ten selected data capturing systems.

Note that the operating costs for bar code and RFID systems were estimated by assuming that at least 50 RFID tags were needed for each PDT. Theoretically, tags can be used for an unlimited number of times. However, it is assumed that tags will be used a thousand times, the equivalent of 50,000 bar code labels (50 x 1,000). The operating costs were based on the following average market prices:

For RFID tags:

$$50 \times \$8.00 = \$400$$

For 1,000 bar code labels:

$$\text{Ribbon/roll} = \$20$$

$$\text{Labels} = \underline{\$30}$$

$$\text{Total} = \$50$$

$$\text{Total for 50,000 labels (50 x \$50)} = \$2,500$$

Therefore, the operating cost ranges between \$400 for RFID systems and \$2,500 for bar code systems. Note that bar code printer prices (average \$500) are included in the system cost.

Table 4. Description of system attributes

Systems	1	2	3	4	5	6	7	8	9	10	
Type	RFID	RFID	RFID	RFID	RFID	Bar code	Bar code	Bar code	Bar code	Bar code	
Distance between data carrier and PDT	0.40-11.6 inches	2	6	11.6	2	3	0.4	6	7.5	4	3
Technology writing ability	y/n	n	y	y	y	y	n	n	n	n	n
Maximum throughput	0.02-11 Mbps	0.019	2	11	1.8	0.019	0.38	11	11	2	1
CPU speed	8-200	40	100	80	60	8	33	200	33	8	66
Operating system	Dos/Win	Dos	Windows	Windows	Windows	DOS	DOS	Windows	DOS	DOS	DOS
Base RAM	128 KB-16 MB	0.256	16	16	1	0.512	0.128	4	8	0.64	0.256
Maximum RAM	1MB-64 MB	1	64	64	32	1	1	32	2	6	2
Hard drive/PC card	1 MB / 4MB	0.175	0.52	0.52	1	0.175	1	4	2	3	2
Screen dimension	4x16-16x20	4	8	8	4	4	8	8	4	16	8
No. of keyboard keys	17-56	27	56	43	17	24	23	56	38	46	45
Weight including battery	7 oz-44 oz	7.2	40	24	12	7.2	9	21	12	24	44
Battery life	8 hrs - 100 hrs	100	40	100	18	70	100	10	8	40	20
Built-in wireless capability	y/n	n	n	y	n	n	n	n	n	n	n
Technology security	y/n	n	n	n	n	n	y	y	y	y	y
Data carrier	y/n	y	y	y	y	y	n	n	n	n	n
environmental resistance											
Reader rugged characteristics	y/n	n	y	y	y	n	y	y	y	n	n
Ability to read without a line of sight	y/n	y	y	y	y	y	n	n	n	n	n
Resistance to adverse effect(anticoollision , and metal)	y/n	y	y	y	y	y	n	n	n	n	n
Initial investment	\$1,075-\$6,500	\$1,075	\$6,500	\$3,200	\$2,800	\$2,100	\$1,826	\$4,085	\$4,000	\$4,295	\$2,700
Operating cost	\$200-\$2,500	\$250	\$400	\$300	\$250	\$200	\$2,500	\$2,500	\$2,500	\$2,500	\$2,500

Table 4 also shows that most system *capability* attributes except the *type of the operating system* and *built in wireless capability* attributes are quantitative in nature. All system *reliability* attributes require subjective judgment because the user has to specify his preference that systems meet or not meet the attribute described. *Economic merit* attributes, the technology's initial *and operating costs*, are quantifiable. As described earlier, level of technology risk for bar code or RFID is a subjectively rated. It was discovered that systems attribute measures have wide ranges. Figure 10 indicates the variation in measuring ranges, which emphasizes the need for the MAUM to evaluate the systems considered. For confidentiality reasons, brand names are not revealed. Numbers refer to systems.

3.6-Measuring Weights

To obtain information about the preferences of the technicians and ITPs in construction material testing labs, 23 individuals from six different construction material testing labs were interviewed to understand their preferences and to construct the attribute utility curves. The completed survey is found in Appendix E. The interviews averaged 73 minutes, but ranged from 55 minutes to 85 minutes. The respondents were asked to answer hypothetical questions, based on the theory introduced in Chapter 4, that involved their preference of PDT attribute weights and utilities.

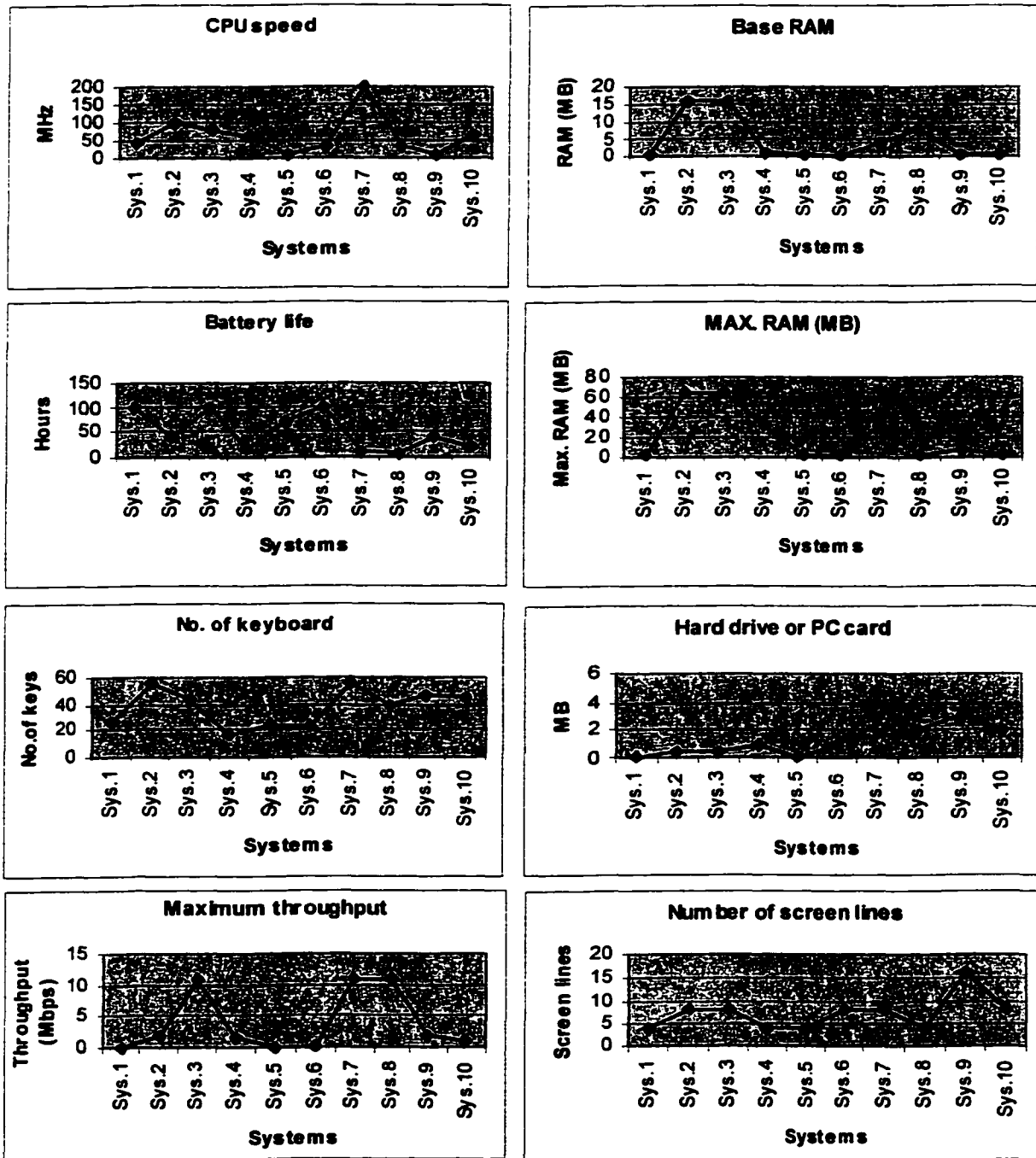

Figure 10. Variations in attribute ranges

Each interviewee was asked to rate the relative importance of each attribute under each objective on a 100-point scale. All weights are normalized to one. Part I in the questionnaire in Appendix E is designed to obtain information about attribute weights.

3.7-Checking Attribute Utility Independence

Before constructing the single-utility curves, it was verified that each attribute is utility independent of other attributes. As mentioned in Chapter 2, this utility independence can be analogized as the respondent being indifferent between the two lotteries shown in Figure 11 where Y and Z can be any two attributes in the model.

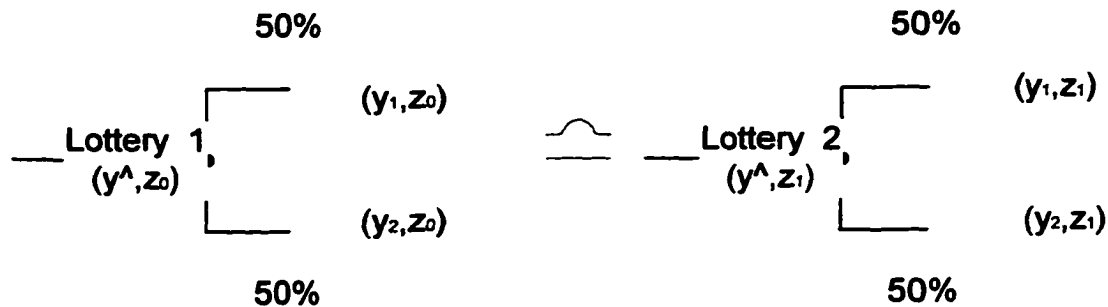

Figure 11. Verifying utility independence

Keeney and Raiffa (1976) reported that to satisfy the utility independence condition practically, Y and Z can be divided into four equal subsections, corresponding to five utility levels (0, 0.25, 0.50, 0.75, and 1.00). For the two attributes, the utility points are expressed

as $[y_0, y_{0.25}, y_{0.5}, y_{0.75}, \text{ and } y_{1.00}]$ and $[z_0, z_{0.25}, z_{0.5}, z_{0.75}, \text{ and } z_{1.00}]$, respectively. If lottery 1 and lottery 2 for each possible (y, z) pair taken from these two groups was found to be utility independent, then it is justifiable to assume that Y and Z are utility independent.

For each attribute, the respondent was directed to consider whether there would be any difference in his preference for the considered attribute if other attribute levels changed. For all points in the question, if he verified that his preference would be the same, then it was assumed that Y was utility independent of Z . This procedure was verified for all attributes in the questionnaire to be sure that all attributes are independent.

Once attributes were known to be utility independent, the next step was to assess the single utility function for each attribute. The following paragraphs explain this procedure for quantitative and qualitative attributes.

3.8-Procedure of Constructing Single-Attribute Utility Functions

3.8.1-Quantitative attributes

During the interview process, the meaning of system attributes was made precise. The evaluator had to define his utility curve for each attribute along the attribute measuring scale by answering questions in Part II in the survey. These questions were derived from the concept of

the lottery explained in Chapter 2. Figure 12 shows a sample question used to elicit the data for constructing the utility function for the *reading distance* attribute. As in all questions, the measuring scale for each attribute is known and is used to normalize the attribute utility function. For example, the utility corresponding to the lowest point in the measuring scale was set to equal zero, i.e., the reading distance attribute, $U(0 \text{ inch})=0$ and the utility of highest point in the range was equal to one ($U(12 \text{ inch})=1$). The evaluator then was required to answer the question in three steps. In the first step, the evaluator determined a subjective mid-value point, called Y , in the interval from the lower to upper range to correspond to a utility of 0.50, i.e., $U(Y)=0.50$. In the second step, the question in Step 1 was repeated for the interval (lower range, Y) to attain the attribute measure corresponding to a utility of 0.25.

In the third step, the same question is repeated for the interval (Y , upper range) to attain the attribute measure corresponding to the utilities of 0.75. Finally, these points were plotted, and a curve was fitted through these five points. The curve equation was also calculated for each quantitative attribute. Each PDT system was rated based on where its attributes fit on the user utility curves.

3.8.2-Qualitative attribute utilities

The rating for the “qualitative” attributes was subjectively made on a ten-point scale, with the “zero point” assigned to complete user dissatisfaction, and the “10 point” for complete satisfaction. Part III in the survey contains questions for qualitative attribute utilities. The questions explore the interviewee’s preferences for the existence/non-existence of the attribute under consideration in the PDT system. All systems that have this attribute get the same rating.

For example, PDTs that have rugged characteristics get the same rating; others that do not have this characteristic get lower ratings. It is not possible to draw utility curves for such questions. Therefore, the interviewee’s direct ratings are used for each non quantifiable attribute.

3.9- Calculating Lower Level Objective Utilities

To obtain utilities for system capability, reliability, cost, and risk, the single-attribute utilities under each objective set are multiplied by the assigned weights and summed. System capability and reliability utilities are combined to obtain the technical merit utility. Economic merit utility is calculated by aggregating cost and risk utilities.

PART II: DETERMINING UTILITIES OF QUANTITATIVE ATTRIBUTES

ATTRIBUTE # 1: Distance between data carrier and reader
Range: 0.4-11.5 inches

STEP 1:

If you have two ways to win a data capture reader by:

1- **Entering a gamble in which there is:**

A 50 % chance to win a reader with 0.40 inch reading distance
A 50 % chance to win a reader with 11.5 inch reading distance

OR

2- **Receiving a reader with a certain reading distance (sure thing!)**

What would be the reader's reading distance that leaves you indifferent between the "Sure thing" and the "Gamble"?

Indifferent point: Inches (Please call it *Y*)

STEP 2:

If the gamble rules changed as follows:

A 50 % chance to win a reader with 0.40 inch reading distance
A 50 % chance to win a reader with *Y* inch reading distance (from step 1)

What would be the reader's reading distance that leaves you indifferent between the "Sure thing" and the "Gamble" in this case?

Indifferent point: Inches

STEP 3:

If the gamble rules changed again as follows:

A 50 % chance to win a reader with *Y* inch reading distance
A 50 % chance to win a reader with 11.5 inch reading distance
What would be the reader's reading distance that leaves you indifferent between the "Sure thing" and the "Gamble" in this case?

Indifferent point: Inches

Please indicate whether your preference would be different if other attribute levels changed?

Yes ()

No ()

Figure 12. A sample question to construct the reading distance utility function.

3.10-Determining Objective Interactions

Winterfeldt and Ward (1986) reported that objective interactions occur at higher objective levels. To calculate the intermediate utilities (technical and economic merit utilities), objective interaction weights should be calculated. Calculating interaction weights is based on the concept of hypothetical lotteries (see Section 2.2.7.2.2). Figure 13 is an example of questions in Part IV of the survey that were used to explore the respondent's indifference probabilities and were in turn used to calculate the interaction weights between the two objectives (technology capability and reliability).

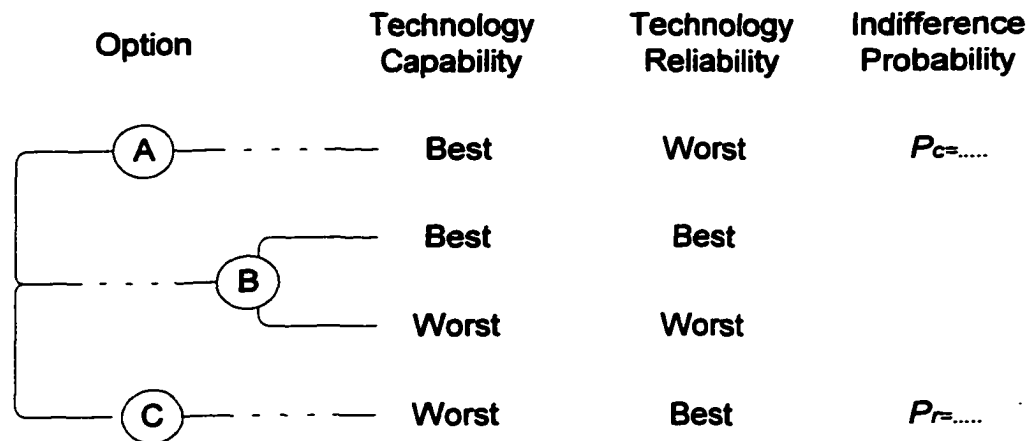

Figure 13. Example of using the hypothetical lottery to calculate the interaction weights using the indifference probabilities

The survey results emphasized a complementary relationship between system capability and reliability objectives and a supplementary relationship between system cost and risk, as well as between the technical and economic merit objectives.

As Keeney and Raiffa (1976) reported, it is reasonable to integrate different additive and multiplicative utility functions over separate regions of the model. It is also reasonable to nest multi-attribute utility functions inside each other. Accordingly, the final form of the model is as depicted in Figure 14.

3.11-Model Aggregation

The model integration process proceeded in three stages. As Figure 14 shows, the attributes were distributed under four lower level objectives (capability, reliability, cost, and risk). Lower level objective utilities were calculated using the additive rule. The capability and reliability objectives are combined to provide the technical merit objective. Cost and low risk objectives are combined to provide the economic merit utility. Finally, the technical and economic merit utilities are combined to find the overall aggregate utility using the multiplicative rule (Equation 11 in Chapter 2). Information to obtain evaluators' indifference probabilities were obtained from questions in Part IV of the survey in Appendix E.

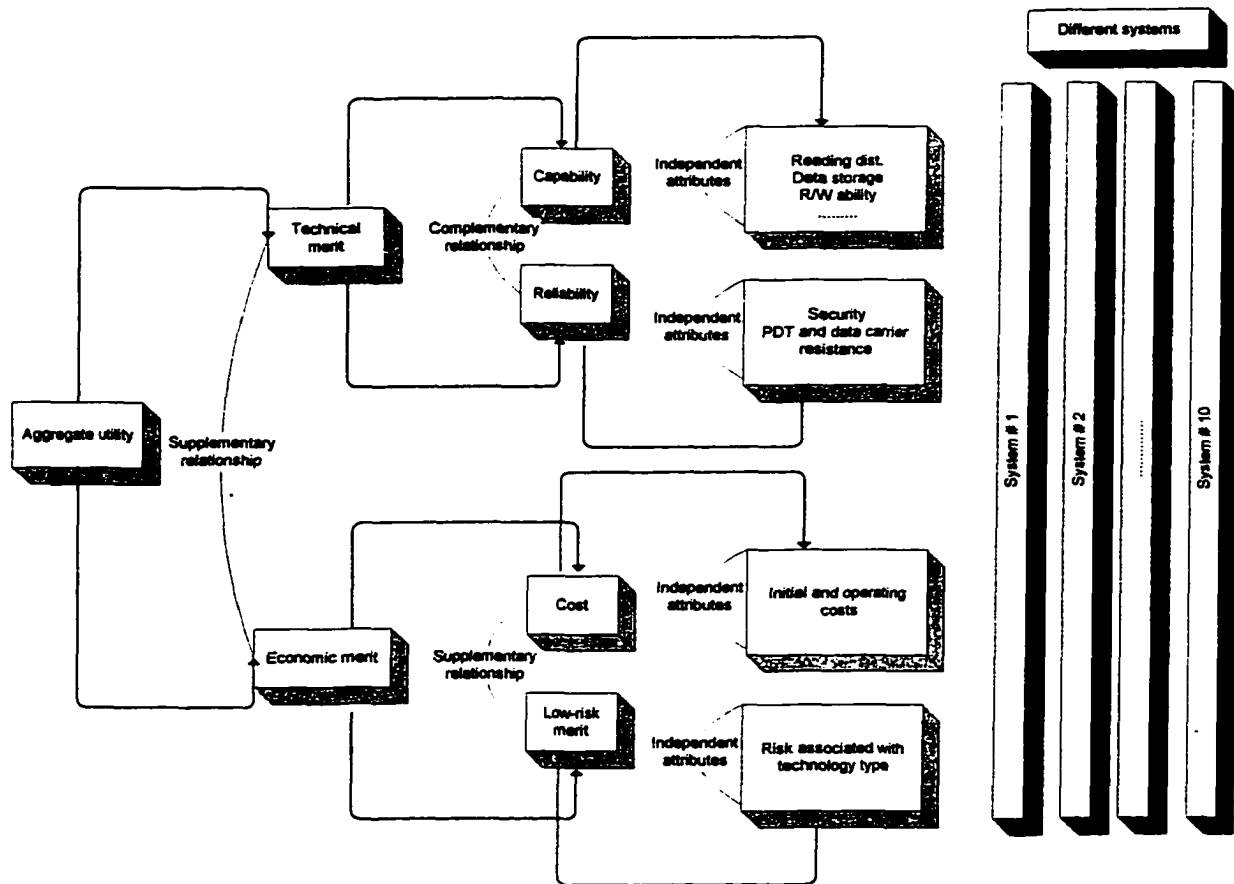

Figure 14. Final form of the model including the interaction relationships

Indifference probabilities are substituted in Equations 12 and 13 in Chapter 2 to calculate objective interaction weights.

3.12-Limitations of the Study

The limitations of this study and of the theory itself are as follows:

- It should be noted that any model cannot fully represent reality. There is always a tradeoff between the degree of complexity and the model's ease-of-use. Adding more complexity to the model,

with the additional cost and effort it entails, should be evaluated against the obtained marginal benefits. A good model should only incorporate the essential elements of the problem and ignore the less important ones that have no or little effect on the decision.

- Generation of a suitable set of attributes is unique for a specific problem and for specific objectives. Therefore, the utilities derived from the aggregate utility model are relevant only to the objectives from which the attribute structure was derived. If new and different objectives and attributes are introduced, the model should be adjusted accordingly.
- When dealing with attribute dependence, the mathematics underlying MAUM may be cumbersome and complex. To avoid such complexity, attribute independence may be presumed to sacrifice some accuracy (Winterfeldt and Ward, 1986).
- The MAUM can be manipulated to reflect the decision maker's preference. MAUM can be vulnerable to being skewed toward a preferred conclusion. Selecting the main focus of evaluation, method of data collection, attribute weightings and ratings, and aggregation rules can all affect the results. Therefore, given such a possible range of discretion, MAUM can be specified in a variety of ways. However, the premise is that rationality should always be maintained.

- **Constructing utility curves requires answering questions in the survey found in Appendix E. Such hypothetical questions are not easy to answer and require deliberate thinking. It was difficult to find more than 23 individuals willing to participate in this survey. More affirmative results might have been obtained if the sample size had been larger.**

CHAPTER 4. MODEL RESULTS AND ANALYSIS

Data obtained from the survey were used to obtain automatic data capture system merit ranking and to analyze differences in the decision maker's preferences in the participating labs. The survey data were obtained from several groups. The Iowa Department of Transportation (IDOT) represents a large government materials testing laboratory. The remaining labs are smaller private ones. Individuals at both types of labs are either classified as lab technicians or information technology professionals (ITP).

4.1-Summary Results

To obtain systems merit ranking, the aggregate utilities for the portable data terminals (PDT) systems were calculated. The calculations are not presented here, but aggregate utilities for all systems ranged between 0.311 and 0.654, which suggest that evaluators in the sample did not consider any of the systems as perfect enough to obtain an aggregate utility close to 1. Figure 15 shows the system ranking for the overall sample. It should be noted that system utilities are connected using line graphs instead of scattered points. The reason is that this way seems to clearly represent the data and help the reader visualize it better. The first two systems are RFID systems (Systems 3 and 2), while the third represents a bar code system (System 7). This result emphasized the assumption that bar code systems sometimes are more

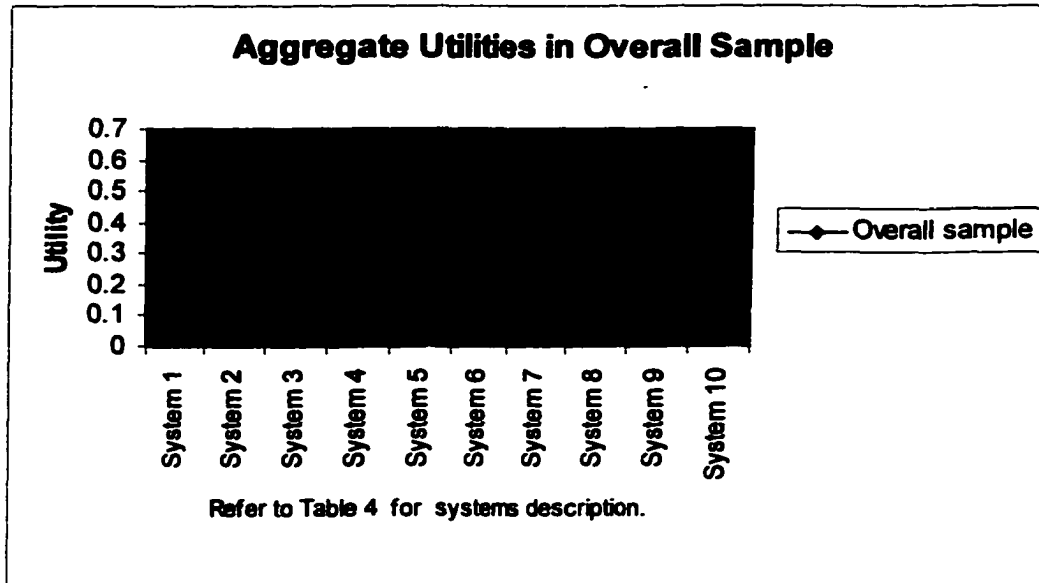

Figure 15. Systems ranking for overall sample

suitable than some RFID systems, as system #7 (a bar code system) is better than systems #1, #4, and #5 (RFID systems). To understand the results, it may be helpful to compare the first selected three options more closely. Figure 16 shows the capability, reliability utilities, and their aggregation as in the technical merit utilities for all systems. All systems have different combinations of capability and reliability utilities. One system might be high in one utility and low in another.

System 3 had high capability and reliability utilities, and consequently, the highest technical utility. Although System 2 had a lower capability utility compared to System 7, the technical merit utility for System 2 is higher than System 7, because System 2 reliability exceeds that of System 7.

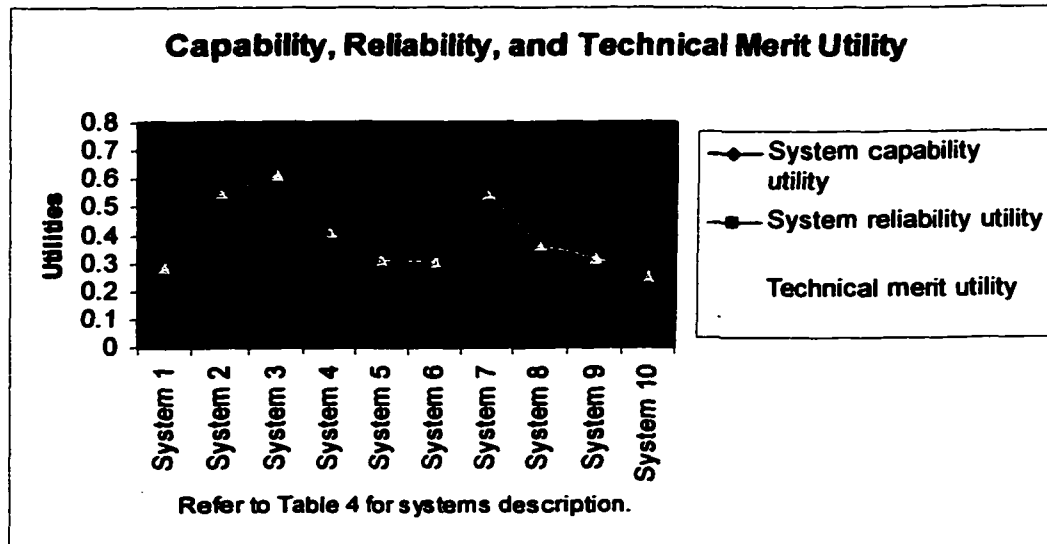

Figure 16. Capability, reliability, and technical merit utilities

Figure 17 shows the cost, risk utilities, and their aggregation in economic merit utilities. Systems of the same type (RFID or bar code systems) are assumed to have the same risk utilities because the risk factor is related to the technology type, not to a specific system configuration. Cost utilities are higher for inexpensive systems such as System 1. The high operating costs of bar code systems (Systems 6, 7, 8, 9, and 10) degraded the total cost utility compared to some RFID systems (Systems 2 and 3) that do not require operating costs.

The supplementary relationship between risk and cost caused the economic merit utility to be improved when either risk or cost utilities increased, because it is acceptable to have either an inexpensive risky

system or an expensive risk-free system, which explains the improvements in the economic merit utilities for bar code systems that have inferior cost utilities because they are less risky than RFID systems.

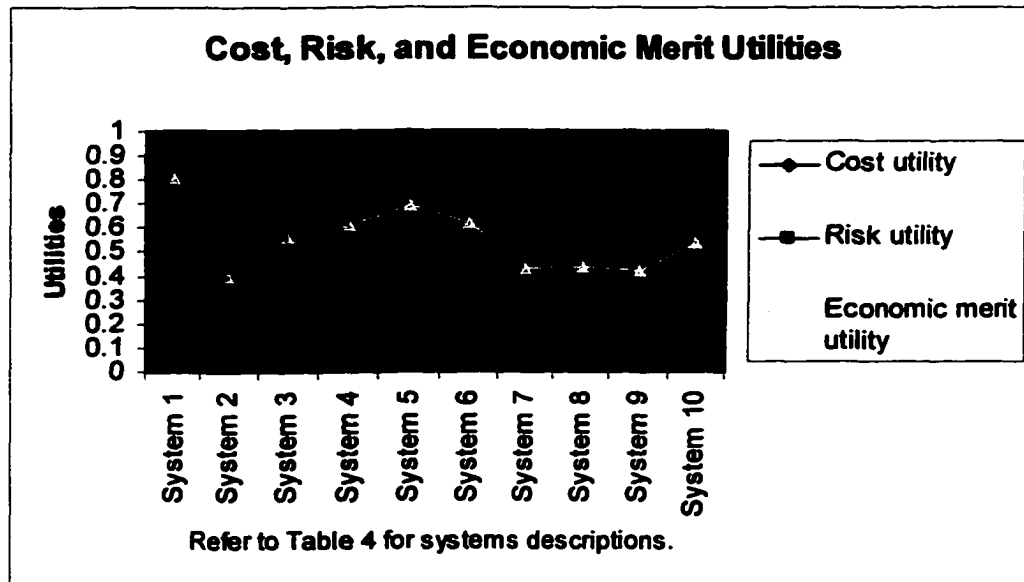

Figure 17. Cost, risk, and economic merit utilities

Figure 18 combines technical and economic merit utilities in the system aggregate utilities. The figure reveals the strengths/weaknesses in the technical/economic aspects of each system. By examining Figure 18, it is possible to see where each system excels, and where it does poorly with respect to technical and economic merits.

System 1, for example, does best in terms of economic merit utility; however, it does rather poorly with respect to technical merit

utility. System 3 has the highest aggregate utility, although its economic merit utility is ranked fourth. System 2 has the second highest aggregate utility, although its economic merit utility is the worst among all systems.

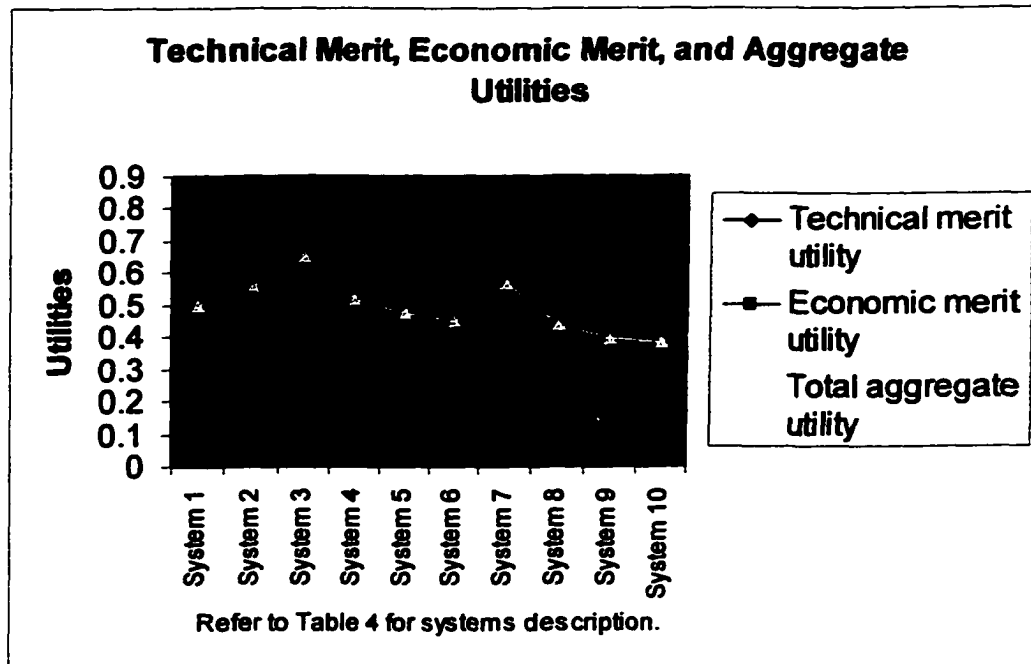

Figure 18. Technical merit, economic merit, and aggregate utilities

4.2-Sensitivity Analysis

The sensitivity analysis involved some additional calculations to examine the effect of changing the model parameters on the final conclusion. The sensitivity analysis in this study involves studying the effect of (1) the variations in the model relationships, (2) changing the PDT prices on the decision, and (3) using the “additive” aggregation rule

instead of the “multiplicative” rule. The following sections explain the effect of these factors in more detail.

4.2.1-Effect of changing model interaction relationships

Because the choice of objective interaction weights is so critical in this analysis, the model calculations were repeated with different objective weights, while maintaining other variables constant. Changing the interaction weights was assumed to have a marked effect on the ordering of the option. The relative importance for each objective was changed to cause changes in weights (-10%, -20%, +10%, +20%). The result was a considerable change in the calculated PDT utilities. However, the results showed that for systems ranked between 1 and 7, the rankings did not change. In this case, changes in objectives weights have no effect on the ranking of top selected systems.

4.2.2-Effect of changing system prices

Leaving the weights unchanged, it was assumed that systems rankings would change if system costs changed. PDT cost might be changed in the future or negotiated with vendors. Based on that premise, systems were re-evaluated using 10%, 20%, and 30% price discounts, dramatically changing aggregate utilities with a minor shifting in system rankings. Only one reversal occurred to Systems 8, and 9, which have very close aggregate utilities.

4.2.3-Effect of changing the model integration rules

The question of whether replacing the multiplicative integration rule with the additive rule would lead to any different result was explored. System aggregate utilities were re-assessed with the additive integration rule. There were minor differences between the two methods. With the multiplicative rule, utilities were always higher than the corresponding additive rule by about 1% to 4.3%. The results depicted in Figure 19 clearly show that there was no change in system ranking.

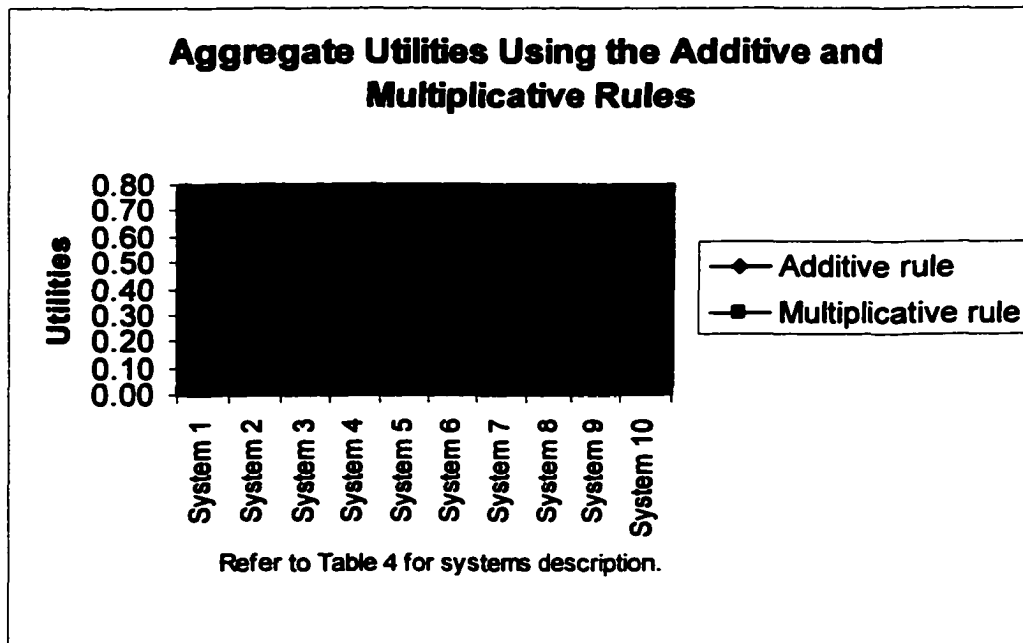

Figure 19. Aggregate utilities using the additive and multiplicative rule

However, the technical and economic merit utilities shown in Figures 20 and 21 are clearly different, although system rankings were not changed.

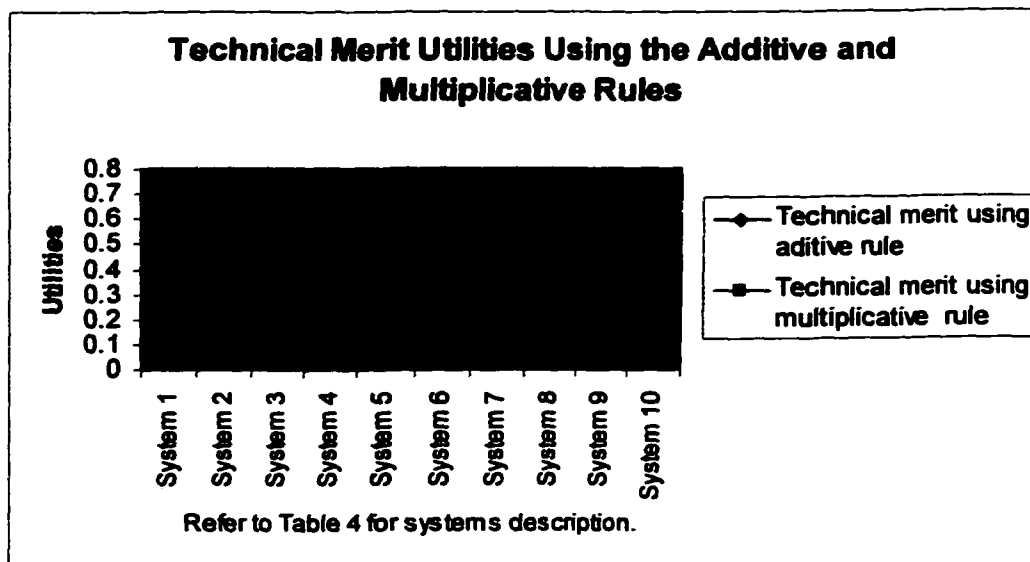

Figure 20. Technical merit utilities using the additive and multiplicative rules

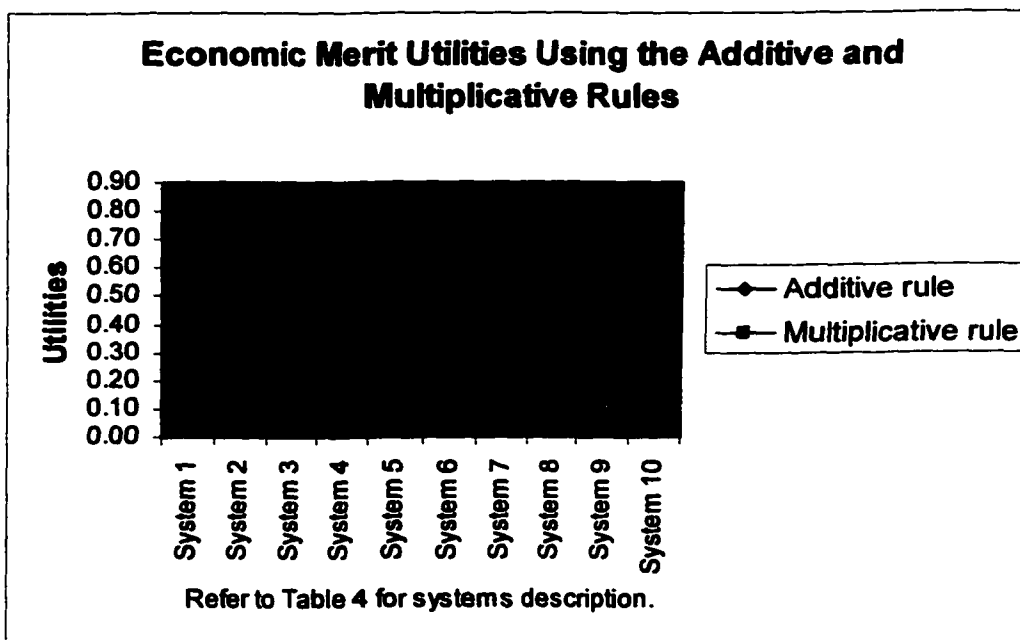

Figure 21. Economic merit utilities using the additive and multiplicative rules

This indicates that the preference ordering for the ten PDT systems is very similar when using “additive” or “multiplicative” rules; however, the use of the additive rule leads to significant changes in the intermediate utilities. For example, the use of the additive rule led to an increase in technical merit utilities by 13% to 33% over utilities calculated using the multiplicative rule.

On the contrary, the use of the additive rule led to a reduction in the economic merit utility values by 1% to 12% of the values calculated using the multiplicative rule. This indicates that using the additive rule overestimated the technical merit utility while it underestimated the economic merit utility. In all cases, however, system rankings were the same.

In conclusion, when the relationship between evaluation objectives is a supplementary relationship, such as the relationship between the technical merit and the economic merit utilities, the multiplicative rule tends to provide larger utilities compared to the utilities calculated using the additive rule. On the other hand, when the relationship between the evaluation objectives is complementary, as in the case of the technical merit utility, the multiplicative rule tends to underestimate the calculated utilities.

When there is a complementary relationship, options are assigned relatively smaller utilities, because a desirable level of one objective is

not of much benefit unless accompanied by a desirable level in the other objective.

Once the systems ranking is confirmed by the previous changes in the model structure and parameters, one needs to determine if other changes in the model might reverse the calculated utilities and ordering of the top ranked systems. Differences in system utilities and rankings might come from the evaluation participants. The hypothesis is that the type of lab (government versus private), and the nature of the individual's job (ITPs versus technicians) affect decision-makers' preferences. Therefore, 348 t-tests were conducted to detect differences in objective interaction weights, attribute weights, and different attribute utility points among the following groups:

- 1- Information technology professionals in government labs versus ITPs in private labs
- 2- Technicians in government labs versus technicians in private labs
- 3- The decision-makers group (technicians and ITPs) in government lab versus the decision-maker group in private labs
- 4- Technicians in government lab versus ITPs in government labs
- 5- Technicians in private labs versus ITPs in private labs

6- All technicians in the sample (from government and private labs) versus ITPs (from the same government and private labs)

Figure 22 summarizes the above six different comparisons made in this study. The figure shows the distribution of the 23 individuals interviewed. Note also that the arrows and numbers (in octagons) next to them refer to comparison numbers listed above.







Labs	ITPs	Technicians	Total
IDOT	 6	←  9 → 	15 
Private	2 ↓	←  6 →	8 ↓
Total	8	←  15 →	23

Figure 22. Six types of data comparisons in this study

The following sections discuss the significant differences between the IDOT Lab and private labs in terms of system rankings and attribute preferences.

4.3-Differences between Government and Private Labs

4.3.1-PDT system rankings for the IDOT and private labs

To obtain system merit ranking by IDOT and private lab decision makers, the aggregate utilities for the PDT systems were calculated. The calculations are not presented here. More details are found in Appendix G.

Overall, there are no differences in top system rankings. The only difference is that Systems 6 and 8 occupied the seventh and eighth ranking position for technicians and reversed their rank for ITPs. Differences in aggregate utilities for all systems by ITPs and technicians in the sample ranged between -11% to 7.36%.

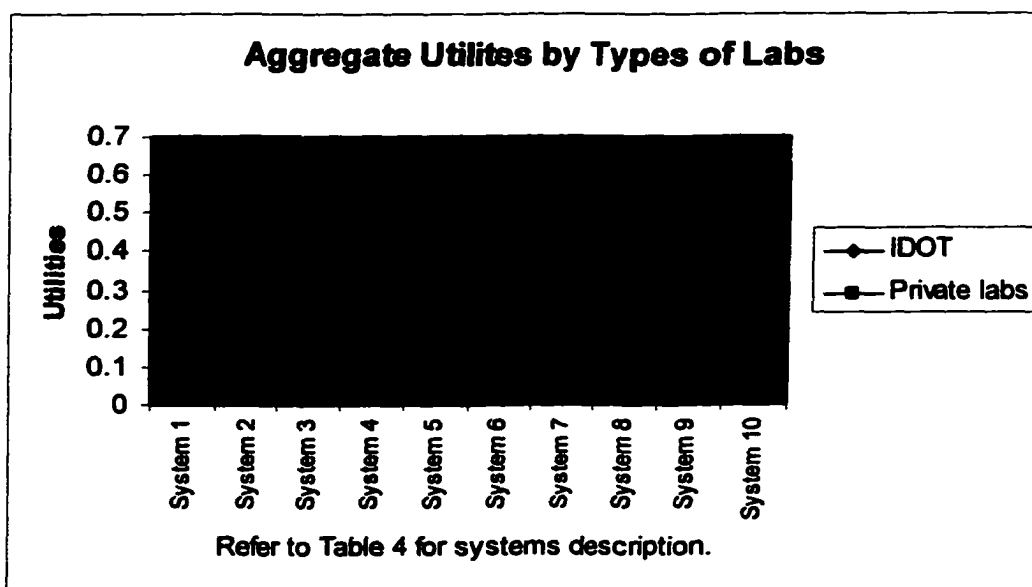

Figure 23. Aggregate utilities for IDOT and private labs

Figure 23 shows that decision makers in private labs provided higher utilities for RFID systems (first five systems) compared to those in the IDOT Lab. On the other hand, decision makers at IDOT assigned higher utilities for bar code systems (Systems 6 to 10).

These findings suggest studying the factors that lead to the above results. Differences among the preferences of government and private

labs are provided in the following next sections. These sections cover comparisons number 1, 2, and 3 in Figure 22. Comparisons are related to viewing model relationship, attribute importance, and quantitative and qualitative utilities.

4.3.2-Differences in viewing model relationships

Interaction objective weights form the model relationship. No significant differences in objectives' weights were reported between private versus government labs. This indicates that technicians and ITPs have similar views regarding the model formation that are structured by the (1) complementary relationships between system capability and reliability, (2) supplementary relationships between system cost and risk level, and, (3) supplementary relationships between technical and economic merit.

4.3.3-Differences in viewing attribute importance

Attribute weights indicate the relative importance of technology attributes. There were no significant differences in attribute weights assigned by individuals in government and private labs except for the cost attribute. ITPs and technicians in private labs assigned more weight to initial cost than did technicians and ITPs in government labs. Private labs care more about spending money, because profit is the main concern. On other hand, ITPs and technicians in government labs assigned more weight to operating costs compared to ITPs and

technicians in private labs. The reason is that government rules make the approval procedure for annual operating costs more complicated in government labs, when cost goes beyond a certain level.

4.3.4-Differences in quantitative and qualitative attribute utilities

Attribute utilities reflect how the evaluator measures the attribute benefits. There were not many significant differences between government and private labs regarding attribute utilities. However, some attribute utilities significantly differed by one or two utility points. The pattern was not very clear and seemed to be spontaneous. For example, one group might have a high utility at one point and then a low utility at the following point compared to another group. Except for these few differences, which seem to be normal, because the two groups could not be exactly identical, one can conclude that the materials testing labs utilities are almost the same in government and private labs.

Among the few significant differences between government and private labs, it was found that technicians in government labs reported fewer higher significant utility points for some of the model attributes such as the *reading distance* attributes and the *number of keyboard keys*. These differences could mean that technicians in government labs are more restrictive in their demands at some utility points.

There was also a significant difference between government and private labs in utilities concerning certainty about bar code and RFID

systems. Decision makers in government labs are more uncertain about RFID technology compared to those in private labs. This might be due to the fact that decision makers in private labs are more likely to be risk takers than decision makers in government labs. Decision makers in private labs might believe that acquiring cutting-edge technology deserves taking a risk to save more time and money.

In general, there are not many significant differences between the IDOT and private lab decision makers, because the type of work in all labs is the same. Consequently, the decision was made to focus more on comparing differences among ITPs and technicians (comparisons 3, 4, and 5 in Figure 22) than on comparing the two different types of labs. The following paragraphs explain the significant differences in system ranking, and in preferences between ITPs and technicians.

4.4-Differences between ITPs and Technicians

4.4.1-PDT system rankings for ITPs and technicians

Qualitative and quantitative utilities, as well as objectives and attribute weights for ITPs, technicians at the IDOT, private labs, and the overall sample were all used to calculate intermediate and aggregate utilities for the ten PDT systems described in Chapter 3. Figure 24 depicts the aggregate utility for ITPs and technicians in the overall sample. For more information about intermediate and aggregate utilities

of ITPs and technicians at IDOT and private labs, as well as for the overall sample, refer to Appendix G.

Figure 24 shows that, in all cases, technicians assigned higher aggregate utilities to systems compared to ITPs.

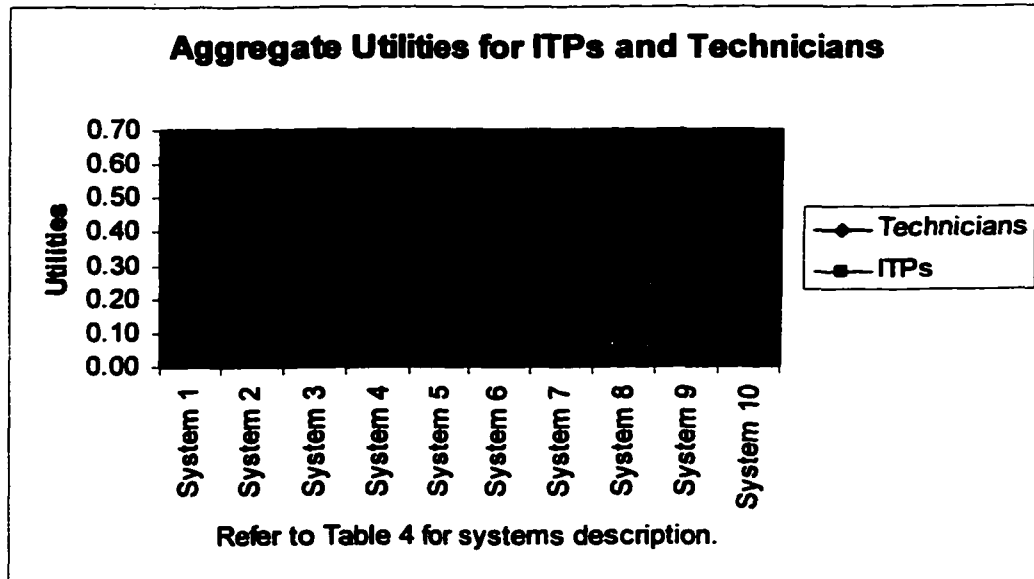

Figure 24. Aggregate utilities for ITPs and technicians

Aggregate utilities by ITPs are lower than those of technicians by 2.19% to 14.36% perhaps because ITPs might have more experience and are more careful in evaluating systems. Although there are some differences in ranking some of the systems, both the ITPs and technicians agreed that systems 3, 7, and 2 have the highest aggregate utilities.

In private labs, the IDOT Lab, and the overall sample, the technical merit utilities for technicians were higher than that of ITPs for the same systems (refer to figure 25). Technical merit utilities by ITPs are lower than that of technicians by 2% to 26.63%, which might imply that because ITPs always work with computers, their satisfaction with new technologies is less than that of technicians, who are less likely to be involved in evaluating computer systems.

Technicians at IDOT assigned higher technical merit utilities for systems more than other technicians in private labs did for the same systems, except for System 7 (refer to Appendix G), meaning that technicians in private labs are more restrictive in their demands than technicians in government labs.

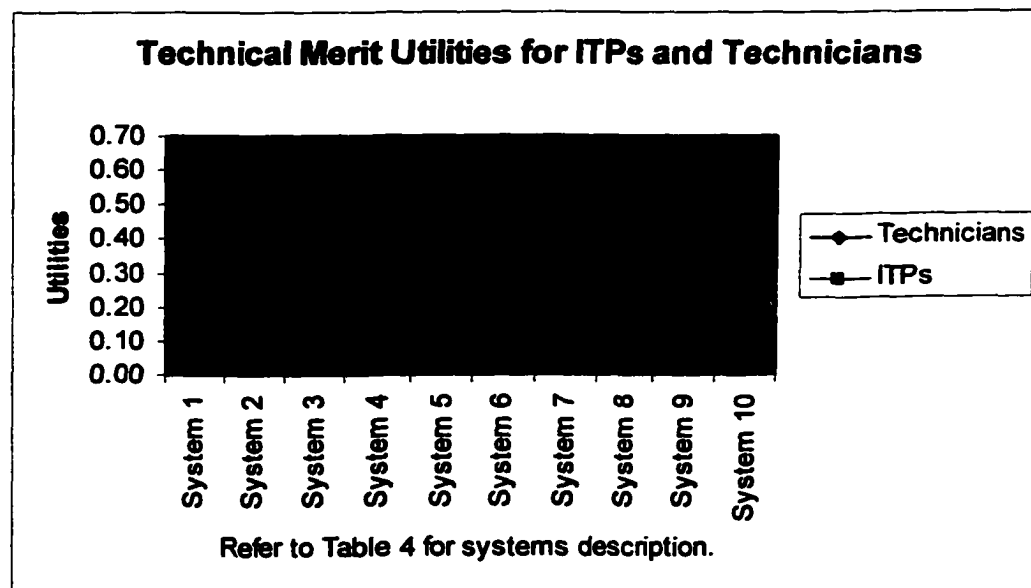

Figure 25. Technical merit utilities for ITPs and technicians

ITPs at the IDOT Lab, private labs, and overall sample assigned higher economic merit utilities for RFID systems but lower economic merit utilities for bar code systems compared to technicians. The reason is that ITPs are probably more willing to accept new technologies and thus assigned higher risk-less merit utilities for RFID systems compared to technicians. Technicians are risk averters because they are not as familiar with the new RFID systems as ITPs are. Consequently, the economic merit utilities assigned by ITPs are elevated for RFID systems.

Figure 26 only depicts economic merit utilities for ITPs and technicians in the overall sample. Differences in economic merit utility ratings by ITPs and technicians ranged between -6.96% to 6.11%. Because there are some variations among technical, economic, and aggregate utilities provided by ITPs and technicians, the following sections discuss factors that led to these differences. The purpose of this comparison is to understand the preference differences between the ITPs and technician groups. Understanding these differences is important, because the decision making in construction organizations depends on who dominates the decision.

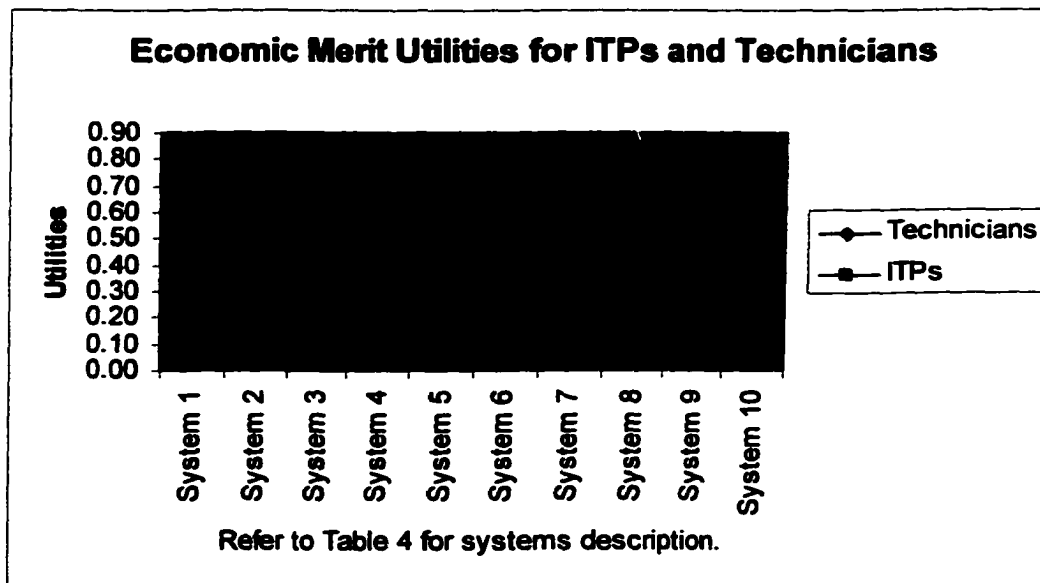

Figure 26. Economic merit utilities for ITPs and technicians

4.4.2-Differences in viewing model relationships

Table 5 shows the average indifference probabilities and the corresponding interaction weights calculated using Equations 12 and 13 in Section 2.2.7, for ITPs and technicians at the IDOT Lab, private labs, and in the overall sample.

Table 5. The indifference probabilities and the interaction weights

		Indifference probabilities									
Capability		0.500	0.322		0.275	0.183		0.381	0.293		
Reliability		0.217	0.389		0.200	0.643		0.194	0.380		
		Interaction weights									
Capability		1.772	0.829	0.097	2.625	0.773	0.084	2.194	0.860	0.001	1.310
Reliability		0.802	1.080	0.054	1.133	1.909	0.057	1.115	1.873	0.090	1.114

The indifference probabilities and interaction weights are calculated for system capability and reliability, system cost and risk, and technical and economic merit. The table shows p-values to check significant differences in the table. Shaded entries in the p-value columns indicate significant differences between the two groups under comparison.

Table 5 also shows that significant differences were reported for the system capability and reliability interaction weights. Overall, ITPs assigned more weight than did technicians for system capability (refer to Table 5). On the other hand, technicians assigned more weight to system reliability compared to ITPs. This indicates that ITPs are more concerned about technical specifications of the PDT system, while technicians are more concerned about durability in the environment.

4.2.3-Differences in viewing attribute importance

Table 6 shows comparisons between significant attribute weights assigned by ITPs and technicians at the IDOT, private labs, and in the overall sample. Attribute weights indicate how each group views the importance of each attribute in the evaluation of different PDT systems.

In the overall sample, as well as at IDOT, ITPs significantly favored attributes related to the technical specifications of the PDT, such as the operating system, base RAM, maximum RAM, and PC card or hard drive more than technicians did. None of these differences, except for the

Table 6. Attribute weights by ITPs and technicians at the IDOT, private labs, and in the overall sample

	Average ITP	Average Technicians	Private Labs	Overall Sample	Overall Sample	Overall Sample	Overall Sample	Overall Sample	Overall Sample
SYSTEM CAPABILITY									
Operating system	0.094	0.110	0.092	0.089	0.099	0.093	0.096		0.094
Base RAM	0.107	0.105	0.025	0.104	0.083	0.284	0.107	0.087	0.097
Max. RAM	0.065	0.054	0.026	0.066	0.051	0.486	0.065	0.048	0.057
Hard drive	0.086	0.071	0.028	0.073	0.062	0.741	0.082	0.061	0.072
Weight including battery	0.053	0.088	0.001	0.044	0.079		0.051	0.077	0.064
Battery life	0.058	0.099	0.002	0.057	0.073		0.058	0.080	0.069
Built-in wireless capability	0.036	0.084	0.013	0.032	0.074		0.035	0.073	0.054
SYSTEM RELIABILITY									
Adverse effect (metal, collision..)	0.199	0.074	0.012	0.212	0.155	0.126	0.202	0.150	0.176
							0.202	0.150	0.176
SYSTEM COST									
Initial investment	0.698	0.615	0.047	0.571	0.659		0.682	0.604	0.640

operating system attribute, could be detected in private labs, implying that ITPs are more oriented toward stronger system performance, because the nature of their job exposes them to the most recent systems.

On the other hand, technicians at the IDOT, private labs, and in the overall sample preferred attributes related to making their job easier, such as PDT weight, battery life, and “built-in wireless capability”. For example, technicians liked lower PDT weights and longer battery life to allow them to work longer without fatigue. Although built-in wireless capability enhances the PDT performance, ITPs did not see it as important as technicians because ITPs are looking for wireless capability that extends beyond lab boundaries to reach remote construction fields, where samples are often taken several hundred miles away.

If wireless capability could extend between the lab and the site, sample information from the field and test results could be exchanged simultaneously. Unfortunately, this feature is not yet available in current configurations. Technicians share the same belief with ITPs, but are more satisfied with the current wireless capability that can only upload test results to a nearby host computer system. Technicians, therefore, rated built-in wireless capability higher than ITPs did (see Table 6).

IDOT ITPs and in the overall sample significantly viewed systems capable of resisting adverse events as more important than IDOT technicians did (see Table 6). Some adverse events might affect RFID systems, such as the signal absorption by a metal surface or collision among multiple tags being read at the same time. Although technicians should worry more about such problems, they underestimated that attribute compared to ITPs. ITPs might have overestimated the threat of adverse effects, because they are unfamiliar with the lab environment. Technicians are more familiar with what causes adverse effects in their labs. This difference in viewing the importance of adverse effects did not prove to be significantly different in private labs (see to Table 6).

Because IDOT ITPs are responsible for technology buying decisions, they significantly viewed PDT initial cost as more important than did IDOT technicians (see Table 6). The case is reversed in private labs, where technicians are responsible for buying decisions. Initial system cost is significantly weighted more in private labs by technicians (see Table 6). In the overall sample, ITPs significantly viewed initial system investment as more important than did technicians (see Table 6). Technicians do not worry as much about IT investment, because they are not involved in daily purchasing decisions like ITPs.

In all, ITPs involved in buying decisions assigned more weight to attributes related to PDT technical specifications and technology cost,

while technicians assigned more weights to attributes related to PDT workability in the lab environment.

The previously mentioned differences in attribute weights among ITPs and technicians suggest that they might have a different attribute ranking. Figures 27 and 28 depict the differences in capability and reliability attribute ranking by ITPs, technicians, and the overall sample.

4.4.4-Differences in quantitative attribute utilities

Table 7 shows some significant utility differences for quantitative attributes among technicians and ITPs at the IDOT lab, private labs, and the overall sample. More significant differences between ITPs and technicians were found at the IDOT lab compared to private labs perhaps because few ITPs at the IDOT work closely with technicians. Most ITPs provide technical consulting for IDOT without close involvement with technicians. The following paragraphs explain significant differences found in Table 7. At some significant utility points at IDOT, in private labs, and in the overall sample, technicians significantly favored faster “system throughput” compared to ITPs. The reason might be that technicians are not very familiar with the exact throughput needed, so they overestimated their need based on a belief that more is better. On the other hand, ITPs might view the test data files as not requiring too much throughput.

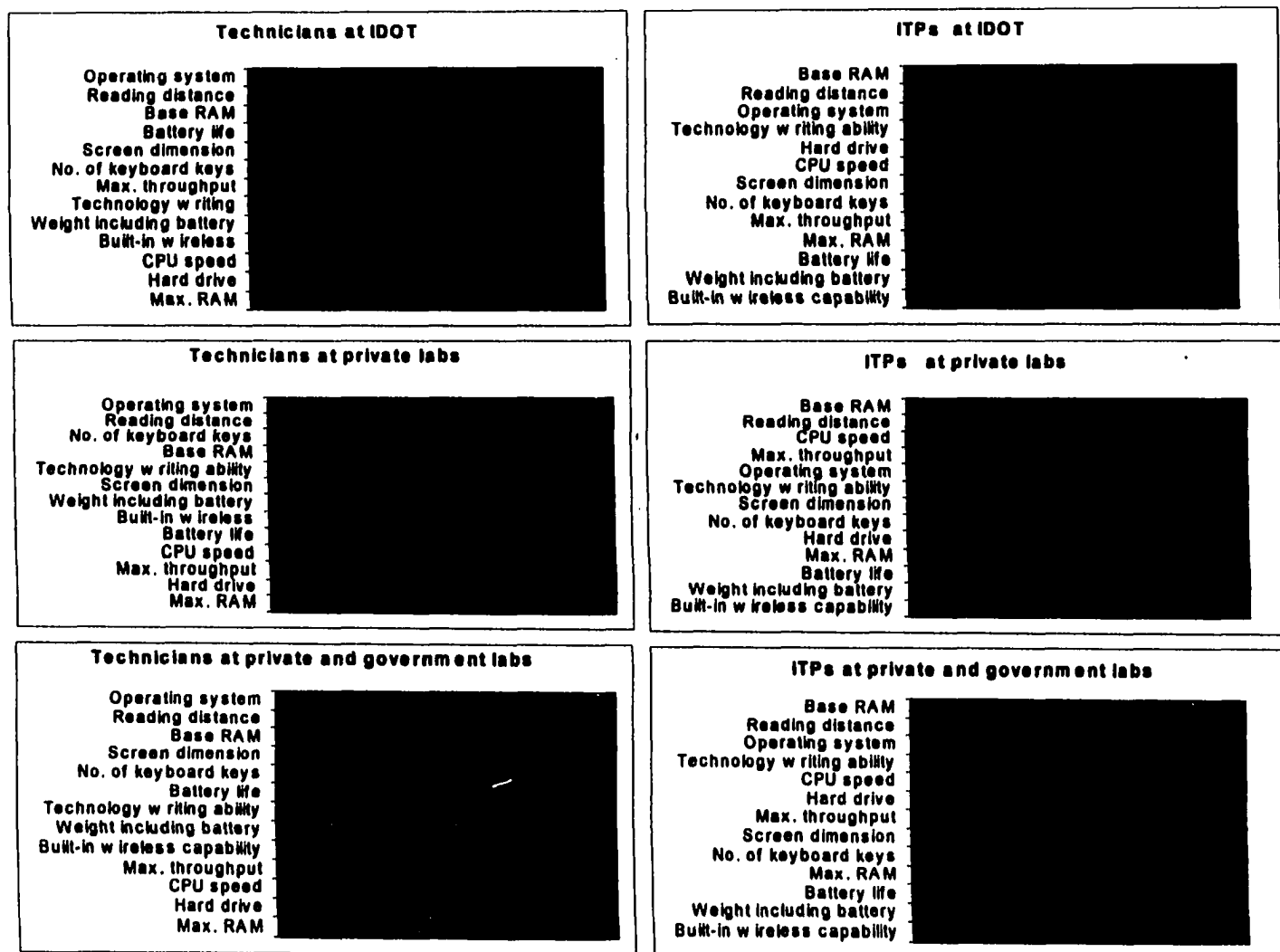

Figure 27. Differences in the rankings of capability attributes by ITPs and technicians at IDOT, private labs, and the overall sample

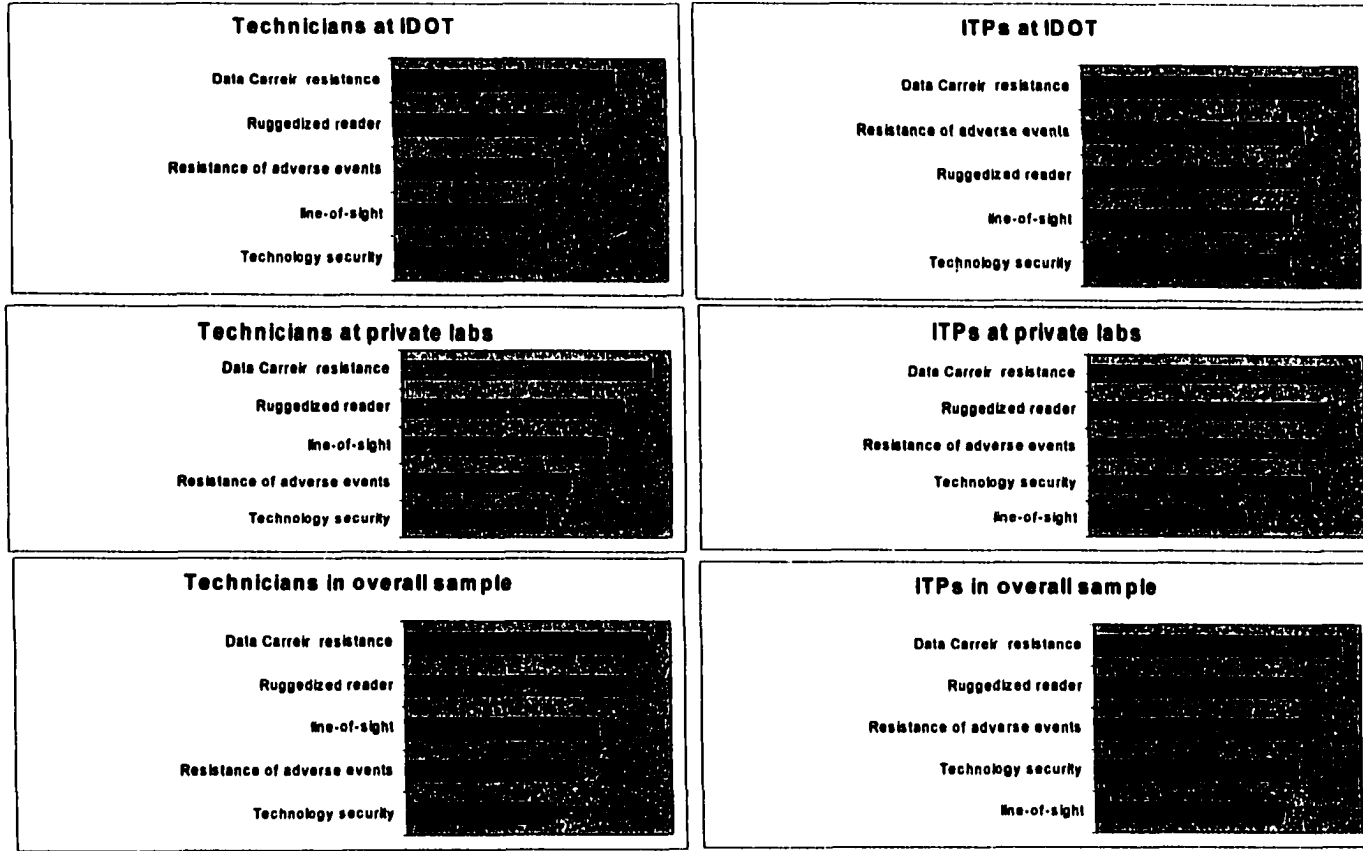

Figure 28. Differences in the rankings of reliability attributes by ITPs and technicians at IDOT, private labs, and the overall sample

Table 7. Quantitative attribute utilities measured at five points

SYSTEM CAPABILITY	0.00	0.25	0.50	0.75	1.00	0.00	0.25	0.50	0.75	1.00	0.00	0.25	0.50	0.75	1.00	0.00	0.25	0.50	0.75	1.00	0.00	0.25	0.50	0.75	1.00			
Distance between data carrier and PDT	0.00	0.00	0.00	0.00	0.00	0.00	0.00	0.00	0.00	0.00	0.00	0.00	0.00	0.00	0.00	0.00	0.00	0.00	0.00	0.00	0.00	0.00	0.00	0.00	0.00	0.00		
	0.25	4.00	4.00	4.00	4.00	1.00	3.33	5.00	5.00	5.00	3.33	4.25	5.00	5.00	5.00	3.73	4.25	5.00	5.00	5.00	3.73	4.25	5.00	5.00	5.00	5.00	3.99	
	0.50	6.00	6.00	6.67	7.00	0.24	6.50	7.00	7.00	7.00	6.50	6.25	7.00	7.00	7.00	6.60	6.25	7.00	7.00	7.00	6.60	6.25	7.00	7.00	7.00	7.00	6.43	
	0.75	8.83	8.83	9.00	9.00	0.73	8.83	9.00	9.00	9.00	8.83	8.88	9.00	9.00	9.00	8.93	8.88	9.00	9.00	9.00	8.93	8.88	9.00	9.00	9.00	9.00	8.90	
	1.00	12.00	12.00	12.00	12.00		12.00	12.00	12.00	12.00	12.00	12.00	12.00	12.00	12.00	12.00	12.00	12.00	12.00	12.00	12.00	12.00	12.00	12.00	12.00	12.00	12.00	12.00
Maximum throughput	0.00	0.02	0.02	0.02	0.02	0.33	0.02	0.02	0.02	0.02	0.02	0.02	0.02	0.02	0.02	0.02	0.02	0.02	0.02	0.02	0.02	0.02	0.02	0.02	0.02	0.02	0.02	0.02
	0.25	1.33	1.78	1.78	1.78	0.33	2.33	2.50	2.50	2.50	2.33	1.63	2.50	2.50	2.50	2.00	1.63	2.50	2.50	2.50	2.00	1.63	2.50	2.50	2.50	2.50	1.81	
	0.50	2.67	4.22	4.22	4.22		4.50	3.50	3.50	3.50	4.50	2.88	3.50	3.50	3.50	4.33	2.88	3.50	3.50	3.50	4.33	2.88	3.50	3.50	3.50	3.50	3.60	
	0.75	4.33	7.11	7.11	7.11		6.67	5.00	5.00	5.00	6.67	4.50	5.00	5.00	5.00	6.93	4.50	5.00	5.00	5.00	6.93	4.50	5.00	5.00	5.00	5.00	5.72	
	1.00	11.00	11.00	11.00	11.00		11.00	11.00	11.00	11.00	11.00	11.00	11.00	11.00	11.00	11.00	11.00	11.00	11.00	11.00	11.00	11.00	11.00	11.00	11.00	11.00	11.00	11.00
Base RAM	0.00	0.13	0.13	0.13	0.13	0.21	0.13	0.13	0.13	0.13	0.13	0.13	0.13	0.13	0.13	0.13	0.13	0.13	0.13	0.13	0.13	0.13	0.13	0.13	0.13	0.13	0.13	0.13
	0.25	6.33	5.33	5.33	5.33	0.21	5.67	8.00	8.00	8.00	5.67	6.75	8.00	8.00	8.00	5.47	6.75	8.00	8.00	8.00	5.47	6.75	8.00	8.00	8.00	8.00	6.11	
	0.50	10.33	8.67	8.67	8.67		9.00	10.00	10.00	10.00	9.00	10.25	10.00	10.00	10.00	8.80	10.25	10.00	10.00	10.00	8.80	10.25	10.00	10.00	10.00	10.00	9.53	
	0.75	13.33	12.67	12.67	12.67	0.23	13.00	14.00	14.00	14.00	13.00	13.50	14.00	14.00	14.00	12.80	13.50	14.00	14.00	14.00	12.80	13.50	14.00	14.00	14.00	14.00	13.15	
	1.00	16.00	16.00	16.00	16.00		16.00	16.00	16.00	16.00	16.00	16.00	16.00	16.00	16.00	16.00	16.00	16.00	16.00	16.00	16.00	16.00	16.00	16.00	16.00	16.00	16.00	16.00
Maximum RAM	0.00	1.00	1.00	1.00	1.00		1.00	1.00	1.00	1.00	1.00	1.00	1.00	1.00	1.00	1.00	1.00	1.00	1.00	1.00	1.00	1.00	1.00	1.00	1.00	1.00	1.00	
	0.25	11.33	12.00	12.00	12.00		12.67	14.00	14.00	14.00	12.67	12.00	14.00	14.00	14.00	12.27	12.00	14.00	14.00	14.00	12.27	12.00	14.00	14.00	14.00	14.00	12.13	
	0.50	25.33	26.67	26.67	26.67		28.00	24.00	24.00	24.00	28.00	25.00	24.00	24.00	24.00	27.20	25.00	24.00	24.00	24.00	27.20	25.00	24.00	24.00	24.00	24.00	26.10	
	0.75	38.67	43.56	43.56	43.56		42.67	40.00	40.00	40.00	42.67	39.00	40.00	40.00	40.00	43.20	39.00	40.00	40.00	40.00	43.20	39.00	40.00	40.00	40.00	40.00	41.10	
	1.00	64.00	64.00	64.00	64.00		64.00	64.00	64.00	64.00	64.00	64.00	64.00	64.00	64.00	64.00	64.00	64.00	64.00	64.00	64.00	64.00	64.00	64.00	64.00	64.00	64.00	64.00
Number of keyboard keys	0.00	17.00	17.00	17.00	17.00	0.42	17.00	17.00	17.00	17.00	17.00	17.00	17.00	17.00	17.00	17.00	17.00	17.00	17.00	17.00	17.00	17.00	17.00	17.00	17.00	17.00	17.00	17.00
	0.25	36.33	34.67	34.67	34.67		34.00	31.00	31.00	31.00	34.00	35.00	31.00	31.00	31.00	34.40	35.00	31.00	31.00	31.00	34.40	35.00	31.00	31.00	31.00	31.00	34.70	
	0.50	43.00	44.61	44.61	44.61		41.33	45.00	45.00	45.00	41.33	42.50	45.00	45.00	45.00	43.40	42.50	45.00	45.00	45.00	43.40	42.50	45.00	45.00	45.00	45.00	42.95	
	0.75	47.67	48.44	48.44	48.44	0.60	48.33	49.00	49.00	49.00	48.33	48.00	49.00	49.00	49.00	48.40	48.00	49.00	49.00	49.00	48.40	48.00	49.00	49.00	49.00	49.00	48.20	
	1.00	56.00	56.00	56.00	56.00		56.00	56.00	56.00	56.00	56.00	56.00	56.00	56.00	56.00	56.00	56.00	56.00	56.00	56.00	56.00	56.00	56.00	56.00	56.00	56.00	56.00	56.00

For the "Base RAM," only one significant difference was found in both the IDOT and the overall sample but none for private labs. IDOT ITPs and in the overall sample have higher utilities for systems with more RAM than technicians have. ITPs, affected by the nature of their job, appreciate lots of RAM more than technicians do. The case is reversed for "Maximum RAM," where ITPs underestimated its utility compared to technicians. The case is very clear at IDOT. No significant differences were reported in private labs.

For the number of "PDT keyboard keys," there is one significant difference in both the IDOT and in the overall sample. The technicians reported more PDT keys were needed than did ITPs (see Table 7), indicating that technicians prefer more PDT keys because it makes data entry easier. Having more keys minimizes combining more than one key to perform operations.

For the "PDT weight," one significant difference was detected in the IDOT, private labs, and overall sample. The technicians favored less PDT weight than did ITPs. This should be expected because technicians prefer to work with lighter weight PDTs.

Technology "initial and operating costs" are major factors for both ITPs and technicians at private and government labs. At IDOT, ITPs had significant lower cost utility curves at many points than technician had, indicating that IDOT ITPs are more concerned about cost because

they are responsible for the purchasing decision. IDOT ITPs also weighted “system cost” more than IDOT technicians did (see section 4.2.3). On the other hand, technicians at private labs care more about cost than ITPs do because they are, in this case, the purchasing decision makers. Likewise, lab technicians at private labs significantly weighted system cost more than ITPs did at the same lab (see section 4.2.3). In the overall sample, many significant differences suggest that ITPs, in general, care more about cost, because they are more involved in technology buying decisions than technician are, a conclusion also reached in section 4.2.3.

4.4.4.1-Differences in utility curves for ITPs and technicians

The significant differences in some qualitative attribute utilities, discussed in Section 4.4.4, resulted in different utility curves and equations for each group. Quantitative utility curves and the corresponding equations were drawn and calculated for ITPs and technicians at IDOT, private lab, and overall sample. Utility curves and equations are performed using Sigma plot software. The binomial equation of a second-degree form best describes the data’s shape and behavior. The resulting equations were used to calculate intermediate and aggregate utilities for PDT systems. Figure 29 only shows examples of the utility curves and equations for some quantitative attributes in the overall sample. Note that the coefficient of determination (R^2), which

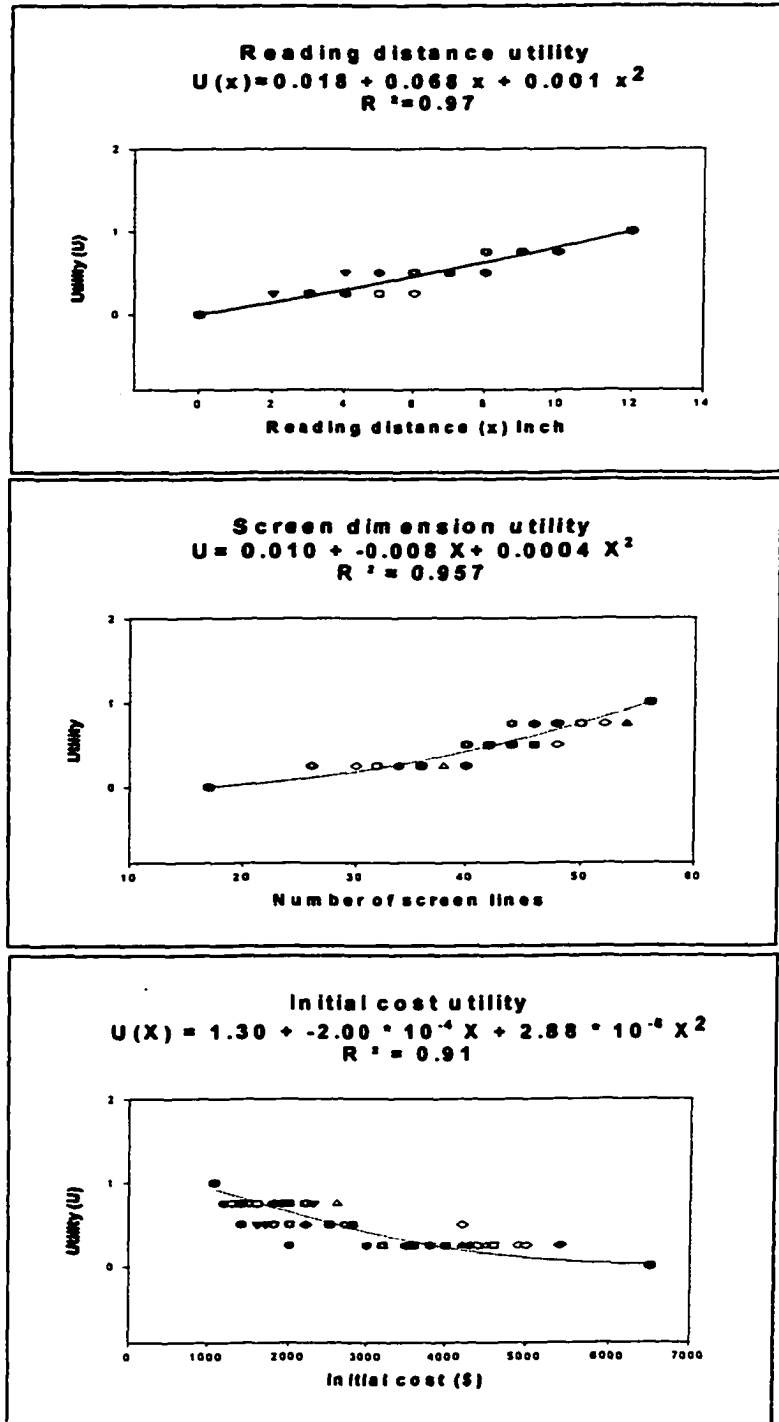

Figure 29. Utility curves for quantitative attributes in overall sample

measures the closeness of fit of the utility curve to its regression line, is found under each equation. Utility curves and equations for ITPs and technicians are not presented here; however, they were used in model calculations. Appendix F contains the utility curves and equations for the rest of the attributes for the overall sample.

4.4.5-Differences in qualitative attribute ratings

Table 8 shows some significant qualitative attribute utility differences between ITPs and technicians at the IDOT, private labs, and in the overall sample. For example, because ITPs considered “Wireless capability” as of no great help because it does not work outside lab boundaries, ITPs at the IDOT and in the overall sample significantly rated wireless capability lower than technicians did. These differences were not significantly reported in private labs.

Concerning “Data carrier environmental resistance,” technicians at the IDOT and in the overall sample rated the utility of “Bar code paper labels” lower than ITPs did, which can be interpreted to mean that technicians are aware of some paper label limitations in labs that ITPs are not.

Technicians, except for those in private labs, significantly rated PDT systems with “Rugged characteristics” better than ITPs did. Technicians may be more concerned about the attributes that help the system survive the lab environment.

Technicians seem to appreciate having systems with the “touch screen data entry method” more than ITPs do. In all labs, there were significant differences between technician and ITP rates, with technicians expressing higher utilities for technologies with touch screens.

ITPs in private labs rated utility for a technology that does not require a “line-of-sight” lower than technicians did. Technicians are looking for better systems that make it easier for them to access data from different directions where there is no line-of-sight between the data label and the reader.

System “Resistance to adverse effects,” such as anti-collision and metal interferences, were significantly viewed better by technicians than by ITPs at the IDOT, private labs, and in the whole sample (see Table 8), showing that technicians are more concerned about proper working conditions.

When it comes to selecting a new “low-risk system,” all technicians in the sample labs significantly assigned lower utilities for RFID systems compared to ITPs (see Table 8). Technicians might be more risk averse than ITPs, who are more willing to accept new RFID systems.

Table 8. Significant differences in utilities for ITPs and technicians at the IDOT, private labs, and in the overall sample

QUALITATIVE ATTRIBUTES										
Built-in wireless capability										
System with built-in wireless capability	4.83	7.56		7.00	8.50	0.15	5.38	7.93		6.65
System without built-in wireless capability	4.67	4.33	0.62	4.00	3.17	0.48	4.50	3.87	0.30	4.18
Data carrier environmental resistance										
Bar code labels										
Paper	5.00	3.44		4.50	3.33	0.31	4.88	3.40		4.14
Plastic	6.17	5.89	0.71	6.50	6.00		6.25	5.93	0.57	6.09
RFID tags										
Coin housing	4.00	4.56	0.57	4.00	4.67	0.60	4.00	4.60	0.41	4.30
Glass housing	1.50	1.44	0.96	2.00	2.50	0.55	1.63	1.87	0.48	1.75
Plastic housing	8.67	8.78	0.86	9.50	8.67	0.25	8.88	8.73	0.75	8.80
PDT rugged characteristics										
Available	7.67	8.89		8.00	8.67	0.42	7.75	8.80		8.28
Unavailable	2.17	1.56	0.27	3.00	2.00	0.27	2.38	1.73	0.29	2.05
Data entry method										
Keyboard	5.83	7.11		5.00	7.83		5.63	7.40		6.51
Touchscreen	7.33	9.00		6.50	9.17		7.13	9.07		8.10
Need for line of sight										
Technology that requires a line of sight	4.50	5.22	0.47	4.00	5.00	0.74	4.38	5.13	0.25	4.75
Technology that does not require a line of sight	7.33	8.11	0.26	8.50	8.00		7.63	8.07	0.48	7.85
Adverse effect (metal, collision..)										
Technology affected by adverse effect	2.17	0.89		2.00	1.33		2.13	1.07		1.60
Technology not affected by adverse effect	7.50	8.56	0.18	8.00	8.17	0.60	7.63	8.40	0.19	8.01
Technology certainty										
Bar code systems	8.33	8.11	0.81	6.50	8.83	0.28	7.88	8.40	0.48	8.14
RFID systems	6.67	3.33		3.50	2.17		5.88	2.87		4.37

Thus far, the previous sensitivity analysis suggests confidence in the model structure, the data incorporated into the model, and the plausibility of the assumptions. Differences among decision makers' preferences affect the calculation of technical, economic, and aggregate utilities. ITPs are more inclined toward technical specifications of systems and greater risk takers, while technicians focus more on system workability and ease of use. It is, therefore, important to combine all of these opinions. MAUM is a flexible tool that enables one to consider all of the decision makers' concerns.

The next chapter provides a summary, recommendations, and conclusions.

CHAPTER 5. SUMMARY, RECOMMENDATIONS, AND CONCLUSIONS

5.1-Summary

The construction industry lags behind other industries in adopting innovative new technologies. By continuously seeking, recognizing, and implementing new technologies, the construction industry can significantly improve the productivity of its processes. Using data capture technologies is one means by which the industry can accelerate its progress.

The most common data capture technologies are bar code and radio frequency identification (RFID) tagging. Although bar code and RFID systems are quite different, they might accomplish the same task. There are also hundreds of bar code and RFID systems on the market, and numerous variations among these systems. Each system has its own technical, economic, and risk considerations that make the selection process a difficult one. Currently, no tool exists to facilitate this decision-making process.

The primary objective of this research was, therefore, to develop a decision tool that enables decision makers in the construction industry to select the most appropriate data capturing technology for their construction application. This decision tool is a systematic evaluation model based upon the Multi-Attribute Utility theory (MAUT).

The model's feasibility as a decision tool was assessed by both laboratory technicians and information technology professionals (ITPs) at six material testing labs, both private and government, in Iowa.

Aggregate utilities were calculated for 10 different bar code and RFID portable data terminals (PDTs). These aggregate utilities simultaneously combine technical-merit, economic-merit, and low-risk merit utilities for PDTs. PDTs were ranked according to their aggregate utilities. Two RFID and one bar code systems achieved the greatest aggregate utilities, indicating that some bar code systems can be better than other RFID systems.

The model sensitivity analysis revealed some similarities and differences among decision makers' views. There were not many significant differences between government and private labs, although private labs are profit oriented and thus more cost conscious, making them more selective in systems technical performance.

The differences between ITPs and technicians in the sample were many. For example, the study showed that ITPs are more concerned about technical specifications of the portable data terminals (PDT), while technicians are more concerned about its environmental reliability. In addition, ITPs are more concerned about attributes such as the operating system, base random access memory (RAM), and hard drive capacity than technicians are. On the other hand, technicians are more

concerned about attributes related to making their job easier such as PDT weight, battery life, and built-in wireless capability.

ITPs, in general, care more about cost, because they are more involved in technology buying decisions than technicians are. The case is reversed at private labs, where technicians make the buying decisions. Technicians are, in general, more risk averters than ITPs, who are more willing to accept new technologies.

There were also some significant differences in ITP and technician utilities that led to different definitions of curves and equations for each group. After quantitative utility curves and the corresponding equations were drawn and calculated, they were used in model calculations.

Because attribute weights and utilities differed for each group in the model, the calculated technical, economic, and aggregate utilities were different. Systems have different combinations of intermediate utilities.

In general, the technical merit utilities for technicians were higher than the same utilities for ITPs. Because ITPs always work with computers, perhaps their interest in new technology is less than technicians, who are less likely to evaluate computer systems. Technicians in private labs are more restrictive in their demands than technicians in governmental labs are.

Compared to technicians, ITPs assigned higher economic merit utilities for RFID systems but lower economic merit utilities for bar code systems. Apparently ITPs are more willing to accept new technologies.

Sensitivity analysis revealed that changes in model interaction relationships had no major effect on the ranking of top systems. Only some minor changes in lower rank systems occurred. The effect of the change in system prices resulted in minor shifting in system rankings. Only one reversal occurred to systems that had very close and low aggregate utilities.

The "additive" aggregation model produced systems ranking similar to the "multiplicative" rule but with considerable changes in technical, economic, and aggregate utility values. The multiplicative model aggregate utilities were always higher than the corresponding additive rule utilities, resulting from the effect of considering the interaction between complementary and supplementary relationships. The intermediate and aggregate utilities were also different. Using the additive rule led to an underestimating of the economic merit utility and an overestimating of the technical merit utilities.

For the two aggregation rules, system rankings were the same. The first two selected systems were RFID systems, while the third was a bar code system. This result highlighted the fact that some bar code systems might be better than other RFID systems.

The stability of the sensitivity analysis results suggested confidence in the model structure, the data incorporated in the model, and the plausibility of the assumptions.

5.2-Recommendations

This research has yielded some important information that construction decision makers can use to evaluate rival data capture technologies. The model developed during this research can also be adapted to evaluate other construction-related applications such as information technologies, construction equipment, building methods, and new projects. Applying the model to these applications would yield invaluable information.

Further research is also needed for such construction-related applications as materials handling, the tracking of construction assets and human resource management. The model can also be used in non typical construction operations such as hazardous waste material operations. The model can take other forms and stress other factors based on the application's unique objectives and decision makers' preferences and utilities.

More research of this type would encourage construction companies to apply the model, exploring and understanding more about decision making's underlying factors. The methodology can also be

computerized in a user-friendly expert system that can make model use and more familiar to all construction decision makers.

5.3-Conclusions

There is no "best" technology that works for all construction applications. The best technology is the one that fits the application needs and users' preferences. It is not possible to recommend a specific data capture system for all construction operations because each construction process is unique and users' preferences differ from one worksite to another. However, a systematic methodology is needed to help construction decision makers do it themselves.

Because the MAUM model provides a general thought-provoking framework to be pursued and built upon, this research recommends that it be used to select the best data capture technology for a specific construction operation. The model is comprehensive because it simultaneously takes into account all technical, economic, and risk factors.

The model is also a flexible tool for accommodating different decision makers' preferences; the research revealed different priorities among ITPs and technicians at material testing labs. Similar differences can be expected in any construction organization. Therefore, it is critical to consider the differences in decision makers' attitudes and preferences. Because they have little involvement in actual construction

operations, ITPs are more concerned with system technical performance. Construction field employees might not be as familiar with technical attributes and thus care more about what makes their job easier in the field. It is, therefore, important to consider both opinions, covering all objectives. The MAUM can work as a group decision-making tool that considers all decision makers' concerns and objectives.

APPENDIX A. SUMMARY OF PREVIOUS RESEARCH RELATED TO BAR CODE AND RFID IN THE CONSTRUCTION INDUSTRY

Many research has been done to introduce bar code and RFID to the construction industry. For example, a study by Bernold 1990 tested the survivability of bar code labels under different heating, freezing, moisture, and adhesive conditions for construction operations. The study recommended careful investigation of the construction environment.

Rasdorf and Herbert 1989 presented how bar code can improve construction inventory control and increase productivity. Blakely 1990 presented the Department of Defense's experience with bar codes and reported its effectiveness for a wide variety of applications.

Stukhart (1989) categorized bar-code applications in construction under five headings: Information management, materials management, process or operations control, time use control, and asset accountability.

Stukhart and Lynn 1991 reported a minimal use of bar code in the construction industry compared to other industries and referred that to the lack of standardization. The research reported the benefit of the standards as the reduction of costs to owners, contractors, and vendors by providing a common format for data exchange, reduction of the paperwork, and time savings.

McMullouch 1994 presented the two-dimensional bar code and discussed its applicability in the construction environment to maintain construction records such as equipment maintenance records.

Bachh 1989 simulates the use of bar code technology in material management and reported productivity enhancement as the use of bar codes reduces human error and speed up the data entry process.

Concerning the use of Radio Frequency Identification (RFID) technology in the construction industry, Only two studies were available. Jaselskis et al 1995 investigated potential applications for RFID in construction industry such as concrete processing and handling, cost coding for labor and equipment, and material control. Jaselskis and Elmisalami 2000 also investigated other new applications for RFID in the construction industry and reported 30 % of time savings on the use of RFID technology in material management.

APPENDIX B. BAR CODE TECHNOLOGY

1-An overview of automatic identification technology

Bar code and RFID systems are two areas of data capture technology that have been gaining momentum in the last two decades and now being seen as radical rivals to enhance data capturing process. Bar code and RFID technologies serve a main purpose of automating data entry process and eliminate two error-prone and time consuming activities: manual data collection and data entry.

(www.aimglobal.org/technologies, 2001).

The next sections highlight the bar code technology. Appendix C contains more information about RFID.

Bar code technology

The first bar code was patented in 1949 in the United States; however, the first commercial use was seen in the late 1960s. Since that, it was considered to be the major widely used identification technology.

There are many bar code symbologies used in a variety of applications. Each symbology represents the rules for character encodation, error checking, printing and decoding requirements, and many other features. There are more than 400 bar code symbologies designed over time. Some of the symbologies are only numeric, or alphanumeric, while others contain the full ASCII set. It is important for each user to use a universal symbology that is supported in his industry. Today, the most popular are ones like the Universal Product Code (UPC), the European Article Numbering (EAN), Code 39, Interleaved 2 of 5 Code, and Code 128...etc. Each code has its own rules of how to print and to interpret the bars and spaces among them. Various symbologies have been developed for particular applications such as retail, manufacturing, transportation, document tracking, libraries, and others. For the one-dimensional bar code, the bars and spaces in each symbology are grouped in such a way to represent a specific ASCII characters. These codes are all public domain symbologies. This means that no one owns the right to monopolize these symbologies, so any company can use these codes to manufacture bar code products. Code 39, is being used in construction and most construction-related applications (Blakey 1990).

1-Types of bar Codes

In general, bar codes can be classified into three main categories: Linear (one dimensional), Stacked, and two-dimensional (matrix bar codes).

1.1-Linear (one dimensional bar code)

This is the most common bar code type and is composed of a series of parallel and varying width of bars and spaces. These bars work as the license plate data holders, typically hold 10 to 20 characters, where they direct the user to information stored in the host computer database (www.in-barcode.com/intro.html, 2001). Most bar codes include an interpretation line contains the same encoded data on the label written in human readable characters underneath the symbol. This Human Readable Interpretation (HRI) allows the user to enter the data manually to the computer in case of the failure to scan a poorly printed or damaged bar code label. Figure 30 shows some examples of bar code symbologies.

1.2-Two dimensional bar codes

In the 1980s, the need to increase the data capacity and information density of bar code symbologies triggered several efforts to drive the development of the two dimensional bar codes. Compared to the one dimensional bar codes, which hold 10-20 characters of information, the two dimensional bar codes can act as the data base that can travel with the item and hold up to several thousand characters. For a two-dimensional symbology application, data look up is not required. In construction industry, two-dimensional bar code is suitable for keeping construction records such as equipment maintenance records. (Mc Cullouch 1994)

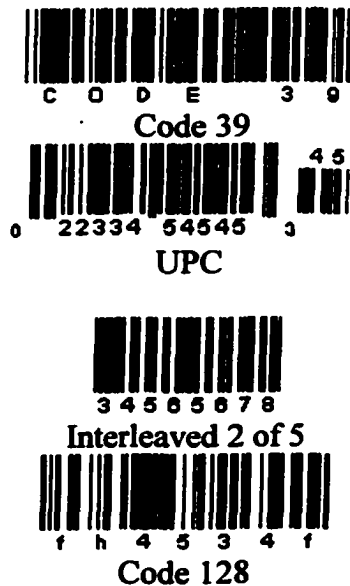

Figure 30. Some examples of one-dimensional bar code symbologies
Source: (http://www.taltech.com/resources/intro_to_bc/bcsymbol.htm, 2001)

Two-dimensional symbologies are much resistant to damage than traditional linear symbologies. For example, some 2-D symbols can lose up to 1/3 of its surface and still be read (Gleen 1998). This is done by building special correction error formulas in the symbol. The most common used 2-D symbologies is PDF 417, data matrix, and matrix code. These symbols are also the public domain for anybody use without paying patent rights. There are two types of two dimensional bar codes: The stacked bar codes and the matrix bar codes.

1.2.1-Stacked bar code

In this type, short Individual linear bar codes stacked on the top of each other. Refer to Figure 31 for different types of stacked bar code (www.aimglobal.com, 2001). This stacked bar codes store relatively a large amount of data (up to 1000 characters) along the height of the code (www.in-barcode.com, 2001). The most successful symbology is the Portable Data File (PDF 417) in which a series of data items can be linked together in one single data base by its decoding process that determines the transition form one row to the next and their correct order (Cohen, 1994) however, stacked bar code is not as efficient as the two-dimensional matrix barcodes (discussed below) in terms of space efficiency.



Figure 31. Stacked bar code

From left to right: Code 16 K, PDF 417, Code 49, and Super Code.

Source: <http://www.adams1.com/pub/russadam/stack.html>

1.2.2- Matrix barcodes

The matrix symbology comprises a matrix of light and dark elements, circles, squares, or hexagons (www.aimglobal.com, 2001). Instead of scanning the widths of bars and spaces, the decoder recognize the presence of light and dark cells in the label and decodes data according to their position (Cohen, 1994). By this way, a bit pattern is created and translated onto ASCII code. This type of bar codes offer huge data densities over the stacked bar code (a ratio of 3 or 4 to 1) (Gleen

1998), however, they are omni-directionally scannable which made it difficult for popular applications to emerge (www.in-brcode.com, 2001). two-dimensional matrix symbol must be read by a camera reader.

Data matrix and maxi-code are examples of 2D symbologies. Contrary to one-dimensional bar code, not all 2-D symbologies are in the public domain which means that some of them require license from the vendor to produce bar code products. This also explains why there are few hardware, such as scanners and printers on the market that deal with these types of symbologies. Figure 32 shows some examples of two-dimensional matrix bar code

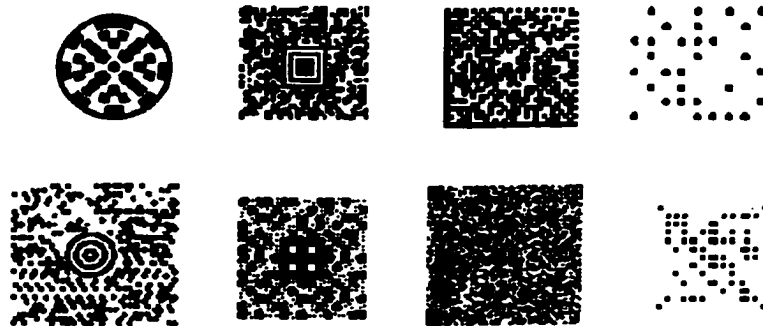

Figure 32. Two-dimensional matrix bar code.

From left to right : 3 DI, Aztec Code, Data Matrix, Dot Code, Maxi Code, Mini Code, QR Code, and Snow Flake Code.

Source: <http://www.adams1.com/pub/russadam/stack.html>

APPENDIX C. RFID TECHNOLOGY

This section provides a general description of the radio frequency identification (RFID) technology. Bar code and RFID systems are similar in that each of them uses a reader and coded data carrier attached to the object. However, bar code systems use optical signal to transfer data between the bar code reader and label, whereas, RFID systems use Radio Frequency (RF) signals to transfer data between the reader and the RFID tag. The RFID tag can contain all pertinent information about the item.

The following paragraphs describe RFID hardware components

1-RFID hardware Components

Radio frequency identification systems typically consist of four basic components:

- Tag, or transponder as a data carrier.
- Antenna to transfer the radio frequency signal from the reader to the tag and vice versa.
- Scanner to generate the radio frequency signal.
- Reader to convert the scanner's analog signal into a digital format to pass the data to the host computer.

In some industrial applications where equipment may be permanently fixed, each of these components is a separate item. In other applications where portability is required, some of the components may be combined into one hand-held configuration. The next paragraphs describe each component in detail.

1.1-Tag, or Transponder

The word transponder is derived from the two words: TRANSMITTER and RESPONDER. The transponder or tag contains an antenna and integrated circuit chip that is encapsulated to protect against the environment. Tags are programmed with the data that identifies the item to which the tag is attached. The tag can be either read-only, read once/write many (WORM), or volatile read/write. Read-only tags are low capacity tags; usually hold approximately 8 to 128 bits of memory and used for identification purposes, WORM tags are read only; though the user can program them one time. In read/write tags, the user can alter the information on the tag as many times.

In general tags require very small powers of micro to milli-watts (www.aimglobal.org, 2001). Tags can be either passive or active, based on the manner in which the tag derives its power.

Active tags are powered by an internal battery to power the tag transmitter and receiver. Although passive tags do not use a battery to boost the energy of the RF signal, it may use a battery to maintain

memory in the tag, or power the electronics that enable the tag to module the reflected signal.

Passive tags are also constrained in their capacity to store data and their ability to perform well in electro magnetically noisy environments. Passive tags, as they only reflect transmission from a reader, are smaller and cheaper than active tags, and also have unlimited lifetime compared to active tags. Active tags, in general, allow higher data transmissions rates, greater communication range, and better noise immunity. (Intermec, no date). Figure 38 shows different shapes of tags manufactured by Trovan and Intermec.

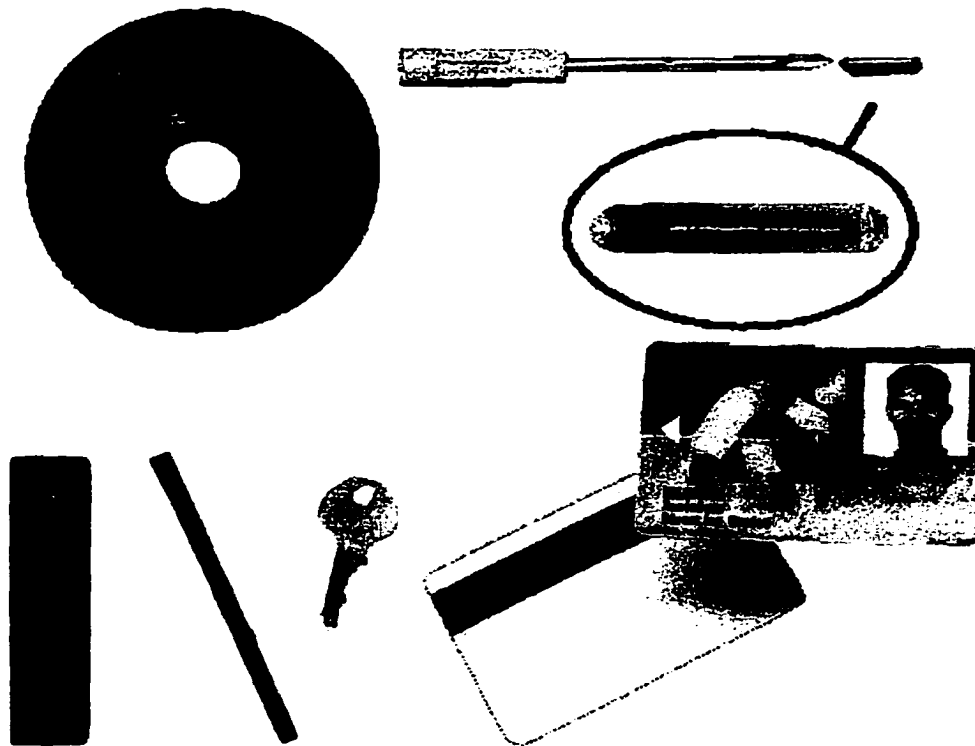

Figure 33. Tags manufactured by Trovan and Intermec

1.2-Antenna

The antennae is used to transfer and receive the radio frequency signals. Most RFID systems include one antennae. Some systems include two antennas; one to transmit and the other to receive the RF signal. Antennas vary in size and shape to meet different applications. They can be freestanding or imbedded in other structures such as in a

concrete block wall to detect personnel badges or passersby (Floyd, 1993).

1.3-Scanner or transceiver

The scanner's role is to generate the energizing signal transmitted from the antenna to the transponder, and filters and amplifies the backscatter data signal (Telsor, no date a). Scanners are configured separately or enclosed with the reader.

1.4-Reader

Readers convert the scanner's analog output into the digital format to be uploaded to the host computer. Reader also monitors incoming signals from the transponders to ensure valid tag data and error-free operation (Telsor, no date b). Depending on the applications, readers come in either stationary or hand-held configurations. Stationary models have greater reading ranges compared to portable models. Portable models are used in warehouses and fields (What is RFID, 1996). Figure 39 shows two models of Intermec Sabre 1555 and Trovan GR 68 portable bar code and RFID readers that include antennas and scanners.

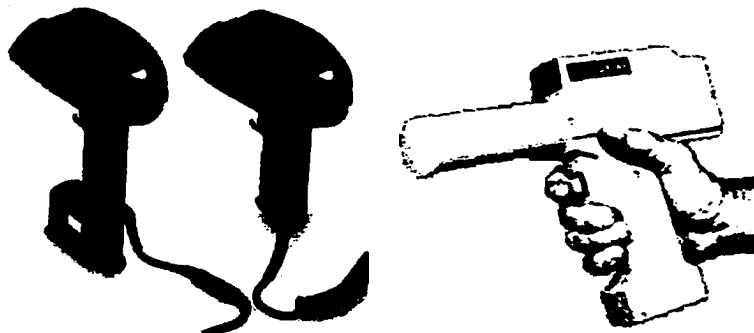

Figure 34. The Intermec Sabre 1555, and Trovan GR 68 readers

2-Frequency and data transmission techniques

Choice of field or carrier wave frequency is of primary importance in determining data transfer rates. In practical terms the rate of data transfer is influenced primarily by the frequency of the carrier wave or varying field used to carry the data between the tag and its reader. Generally speaking the higher the frequency, the higher the data transfer or throughput rates that can be achieved.

RFID technology uses frequencies within the range of 100 kHz to 5.8 GHz. Three carrier frequencies received early attention, as representative of the low, intermediate, and high ranges. These are 125kHz, 13.56 MHz and 2.45 GHz.

Two methods distinguish and categorize RFID systems, the first is based upon close proximity electromagnetic or inductive coupling (125 KHz and 13.56 MHz systems), and the second is based upon propagating electromagnetic waves (2.45 GHz systems). Coupling is via 'antenna' structures forming an integral feature in both tags and readers. In the inductive coupling, the reader's antenna generates a magnetic field that induces a voltage in the tag coil to supply the tag with energy. The transmission of data from the reader to the tag is made by changing one of the transmitting field parameters (amplitude, frequency, or phase). Because the operating field of such systems are in the "near field" of the reader antenna. Reading power decreases with 6th order of distance. That makes the adverse effect of adjacent systems much lower compared to UHF and Microwave systems where the power level decreases as the square of the distance. However, compared to the UHF and microwave systems, the radio frequency field for the frequencies less than 13.56 MHz is not absorbed by water or human body, which have no affect on performance.

Contrary to low frequency RFID systems, which operate on the induction principal, RFID systems that operate on UHF frequency make use of electromagnetic wave propagation to communicate with the tags. The reader transmits the electromagnetic wave, which propagates outwards with spherical wave front. The electromagnetic energy propagates through the atmosphere, or any other material by exciting electrons, which in turn radiate energy at the same frequency which also excite other nearby electrons and so on. ([www. aimglobal.org](http://www.aimglobal.org)) Transponders in the field collect some of the energy depending on the location and may be expressed as $1/d^2$ where d is the distance from the transmitter. UHF systems and microwave RFID systems operate in the "far field" of the reader antenna. Reading distances between 2-40 feet is possible for passive tags and longer than 100 feet for active tags depending on microwave frequency, and antenna configuration

3-Data Storage Characteristics

Data can be encoded in the tag in a way that only authorized users can read or write data. The number of data bits or bytes that can be programmed in the tag include the total bytes used by the manufacturer. The amount of data stored on a tag depends on the application. In general tags may contain such information:

- Identification number, in which a numeric or alphanumeric string is stored on the to identify or track items; or as an access key to data stored in a computer, or
- Portable data files containing all pertinent information to the item.

Therefore, data storage capacities may range from a single bit to several kilobytes. The single bit tags are used in retail stores to activate an alarm when unpaid item leaves the store without deactivating the tag. Passive tags are also constrained in their capacity to store data and the ability to perform well in electro magnetically noisy environments. Passive tags are also constrained in their capacity to store data and the ability to perform well in electro magnetically noisy environments.

Tags of data storage capacities up to 128 bits can hold a serial or identification number with parity check bits. Tags with high data storage capacities can be user programmable and are able to carry data files.

4- Reading range

The maximum reading distance from which RFID system can read or write is determined by many factors such as:

- Type of tags (active versus passive)
- The reader power available to communicate with the tag.
- The available tag power to respond.
- Transmission frequency
- Environmental conditions

The degree to which each system is affected by these factors differs. (www.aimglobal.org, 2001)

5-RFID system categories

RFID systems can be classified into:

EAS (Electronic Article Surveillance) systems

EAS are used in departmental stores where a single bit tag attached to each item can detect unauthorized item departure from the store through fixed readers set up at the store exit.

Portable Data terminals (PDT)

These are portable computers with integrated RFID scanners, used in applications where a high degree of variability in sourcing data from tagged items may be exhibited. (www.aimglobal.org, 2001). PDT can be batch oriented, where the data are captured on testing place and transmitted later to a host computer, or Radio Frequency (RF) linked to instantaneously transfer the data to the host.

Networked systems

Tags are attached to moving items, or people and read by fixed readers on certain locations to report to the network information system.

Positioning systems

With the combination of RFID and GPS, a location of an asset or equipment can be tracked through a reader fixed on the asset that reads tag locations. The RFDC sends the information of the tracked item instantaneously to the host computer.

6-Limitations of RFID technology

The limitations associated with the RFID technology are important to be understood. The main limitation of RFID concerns standardization. Currently, most RFID systems are "closed", meaning that one manufacturer's reader cannot read a tag made by another manufacturer, which does not present a problem to closed RFID systems within a factory or a company. However, if a company, such as a construction company, wants to track products and materials from different suppliers and manufacturers, this poses a problem. It might be difficult to get suppliers to agree on a common RFID system, and it would be too costly to purchase a reader for each type of RFID system used. Standardization and multi-tag readers will hopefully solve this problem. This concern would be mitigated if RFID standards are established early on such that all vendors and suppliers are directed to use the same equipment and tagging technology for a given project. Currently, various standards organizations and interested companies are expending significant effort on developing standards for RFID use.

Another limitation of RFID is that metals can hamper RFID operations by blocking and canceling the radio frequency (RF) signals. When placed directly behind metal, the tag is unreadable, because the metal either absorbs or reflects the signal. Mounting tags some distance away from metal objects, however, may minimize this limitation. In any case, tags mounted on metal objects can be successfully read if the tag is raised slightly off of the metal surface or if it includes a metal back plane that is oriented with the antenna.

Interference from nearby RFID systems can also pose communication problems between the reader and tags. The interference is frequency dependent with lower frequencies, creating simple interference concerns, and with high frequencies, resulting in multipathing problems. However, the most evasive interference that affects tags comes from cathode ray tubes. Selecting RFID systems whose frequencies do not interfere with frequencies commonly used near the construction site may alleviate this concern.

Furthermore, batteries wear out on active tags, limiting their life expectancy. When tracking key project equipment from vendor shop to the site, this might not present a significant concern, since the duration is generally short term. A battery management program will need to be implemented, however, for longer life asset tracking requirements.

APPENDIX D. SIMILAR USES OF BAR CODE AND RFID TECHNOLOGIES IN THE CONSTRUCTION INDUSTRY

Although bar code and RFID systems are quite different, they are competing in data capture technologies market. There are more bar code construction applications than there are for RFID. Construction people are more familiar with bar code systems as it is used heavily in the retail industry. However, most of the time the two technologies can do the same job in many construction applications. The biggest challenge is to select the one that best fits the construction operation. This chapter highlights some of the construction applications that can be served by either bar code or RFID systems

1-Design drawings

A bar code label or a wafer-thin RFID adhesive tag can be applied to construction blue prints and important construction documents. Two dimensional bar code label or and RFID tag can include data or instructions that enhance the safety, the quality, and performance of construction activities. Lots of related information pertain to each sheet of drawings may be of a help to field workers. For example, a tag or a label can contain safety instructions for performing a certain activity; or it can contain information describing the activity procedure, material specifications, and may be a quantity takeoffs. It can also link the user through the Web to a certain help page to solve some of the expected problems. Read/Write RFID tags can be updated to include updated information such as the work-in-progress

2-Material receiving

Upon receiving material in a construction warehouse storage area, materials received can be downloaded to material tracking system by scanning a bar code label, or RFID tag that have been applied by the supplier. Bar code labels or RFID tags can be affixed to either material pallets or to individual items such as engineered or bulky items.

The warehouse clerk would position the bar code or RFID reader towards the label or tag to identify items. After finishing all the visual inspection, all information pertain to the received items can be downloaded to the company information system. Read/Write RFID systems allow writing back some information to the tag such as the quantity received, the material status, and the storage location. The company's information system compares the downloaded information to the anticipated material delivery list. If there is no discrepancies, the shipment is passed quickly into the assigned storage area. If the receiving worker see a missed or defective item, she would take a corrective action based and issue a discrepancy report.

Jaselskis and Elmisalami 2001 conducted two pilot tests involved receiving pipe supports and hangers at two Bechtel job sites. The study involved comparing the manual and RFID approach of receiving the material. The receiving cycle had a 30 % time savings compared to the manual approach. Figure 40 shows a Bechtel worker receiving pipe supports using the RFID approach.



Figure 35. Bechtel worker receiving pipe hangers using RFID approach

3-Filed material control

Construction projects receive, issue, and store several types of materials, spare parts, and many other items. When the field workers recall construction item, the warehouse clerk would position a bar code or RFID reader linked to Portable Data terminal (PDT) to the label or tag on the required item. The warehouse clerk confirms the right item before he issues it. He can also update the inventory record and print out status reports.

4-Tracking construction assets (tools and equipment)

With the utilization of a bar code or RFID system and RF link, it is possible to track construction assets such as tools, and equipment, identify them electronically, and track their movements. The warehouse clerk can know where the asset was, and where it is now and, and who has it. This information will be read in seconds and moved to company asset management systems. Lansford et al 1988 reported that workers are less likely to abuse tools when they know that data is captured in company database.

The system can continually update a database with current asset locations as frequently as every several seconds or only every few hours for items that seldom move (Turner, April 1999). The system also can

have the ability to set alarms that will notify security if something moves, when it isn't suppose to, or doesn't move when it should. For instance, a bar code label or RFID tag on a high value asset could be set to signal an alert if the asset starts to move so that it could be located and stopped before it is removed from the facility (Jacobs, 1999). This will enable the construction companies to better control, and maintain their valuable assets.

The National Institute of Standards and Technology (NIST) developed a Real Time Construction Component Tracking System (Comp-TRAK), which involves developing a web-based system for rapidly identifying and spatially tracking manufactured components on job sites (Jaselskis and Elmisalami 2001).

The system integrates RFID and bar code identification systems, 3D long-range coordinate measurement technologies, portable/wearable computers, wireless communications, high-speed networking, temporal project databases, web-based data analysis, and 3D user interfaces to provide *as-is* and *as-built* component data at the actual construction site. Refer to Figure 41 for the project web site.



Figure 36. NIST web site to track construction components

5-Tracking people

Bar code labels and RFID tags can be very helpful for personnel tracking and identification. Some construction companies are currently using time cards supplied with bar code labels to access employee information such as the name, work area, and cost accounting code. Work accomplished is credited to the employee account by scanning the label on the time card.

Current RFID card tags come in two main varieties. The first is a laminated card that looks like a credit card. One face of the card can have photos and other printed on it. Another popular card is constructed by welding components inside a plastic housing, usually 0.06 inches thick (Motorola catalog, 1999.) These versatile passive RFID tags are ideal for recording time-in and out data and permit positive employee ID for tool check-out, job log-on and access to secured areas.

Workers can wear a RFID badge that can be used to check into and out of the jobsite. In other words, an immediate and accurate count of workers will always be known. These badges can also be used to check in and out tools from the tool shed. It is also possible to locate construction workers, engineers on site.

6-Assembly of prefabricated items

In the latest decade, the development of robots has been justified by Japanese construction companies on the grounds of productivity, safety and quality. The Japanese advent of the automated site, a kind of factory that builds itself, will form the centerpiece of development into the next century. By making the site more like the factory, it is possible to solve several problems at once. In other words, the factory concept is one that should be fast coming to construction.

Robots in construction are numerous. Among those applications are material handling, welding, painting; blocks setting, rebar cutting and placing; tiles setting; and concrete pouring. Robots can also be used to assemble construction prefabricated items. These robots can make use of bar code and RFID technologies, where RFID tags will be attached directly to the object, containing all the necessary instructions to control and guide robot operations. The robot, reading instructing form the label or tag, can fine tune itself without any labor intervention to change its settings.

7-Enhancing contractors/suppliers relationship

The relationship between the contractors and suppliers can be managed and enhanced by using the data capture technology. Typically, a construction supplier receives many orders from different contractors in different locations. The supplier provides information to the contractor such as the lot number, date of production, specifications, and installation procedure.

With the combination of a bar code or RFID, and global positioning systems, the contractor can know when the order is dispatched, and track the shipment as it goes. This Real Time Locating System (RTLs) system continually updates the contractor database with current shipment locations as frequently as every several hours or minutes if needed. Based on that the contractor can continually update his schedule if he expects not to get the material on time.

8-Enhancing construction material testing labs operations

The objective of the construction materials testing labs is to determine whether the quality of construction materials used or proposed for use in the construction project are in reasonably close conformity with approved plans and specifications. Bar code is currently used to identify samples in some construction materials testing labs. Some samples are identical in the physical appearance but differ in characteristics such as concrete cylinders and cubes. The effectiveness of the data entry into computer depends on easily distinguishing among samples. Read/ write RFID tags can also work as a data base attached to the sample to maintain all pertinent information about the sample such as the contractor name, description, test date and procedure, and test results. RFID has proven itself in other types of labs such as medical labs, and agricultural labs (Jaselskis and Elmisalami 2000).

APPENDIX E. DATA SURVEY

PART I: DETERMINING TECHNOLOGY ATTRIBUTE WEIGHTS

Q1-Please assign a weight from 0 to 100 to each attribute in the technology *capability group*. Start by assigning a weight of 100 to the most important attribute in the group and then assign other attributes weights relative to 100.

Technology capability	Range	Weight
Distance between data carrier and reader	0.4-11.6 inches	()
Technology writing ability	Y / N	()
Max. throughput	0.02-11 Mbps	()
CPU speed	8-200 MHz	()
Operating system	Win / Dos	()
Base RAM	128KB-16MB	()
Max. RAM	1-64 MB	()
Hard drive	1-520 MB	()
Screen dimension	4x16-16x20	()
No. of keyboard keys	17-56 keys	()
Weight including battery	7-44 oz	()
Battery life	8-100 hours	()
Built in wireless capability	Y / N	()

Q2-Please assign a weight from 0 to 100 to each attribute in the technology *reliability group*. Start by assigning a weight of 100 to the most important attribute in the group and then assign other attributes weights relative to 100.

Technology Reliability	Range	Weight
Technology security	Y / N	()
Data carrier environmental resistance	Y / N	()
Reader rugged characteristics	Y / N	()
Need for a line of sight to read	Y / N	()
Resistance to adverse effect (anti collision, metal effect)	Y / N	()

Q3-Please assign a weight from 0 to 100 to each attribute in the technology *cost group*. Start by assigning a weight of 100 to the most important attribute in the group and then assign other attributes weights relative to 100.

Technology cost	Range	Weight
Initial investment	\$ 1,075-\$ 6,500	()
Operating cost	\$200-\$ 2,500	()

PART II: DETERMINING UTILITIES OF QUANTITATIVE ATTRIBUTES

ATTRIBUTE # 1: Distance between data carrier and reader
Range: 0.4-11.5 inches

STEP 1:

If you have two ways to win a data capture reader by:

1- Entering a gamble in which there is:

A 50 % chance to win a reader with 0.40 inch reading distance
A 50 % chance to win a reader with 11.5 inch reading distance

OR

2- Receiving a reader with a certain reading distance (sure thing!)

What would be the reader's reading distance that leaves you indifferent between the "Sure thing" and the "Gamble?"

Indifferent point: Inches (Please call it **Y**)

STEP 2:

If the gamble rules changed as follows:

A 50 % chance to win a reader with 0.40 inch reading distance
A 50 % chance to win a reader with **Y inch reading distance (from step 1)**

What would be the reader's reading distance that leaves you indifferent between the "Sure thing" and the "Gamble" in this case?

Indifferent point: Inches

STEP 3:

If the gamble rules changed again as follows:

A 50 % chance to win a reader with **Y inch reading distance**
A 50 % chance to win a reader with 11.5 inch reading distance
What would be the reader's reading distance that leaves you indifferent between the "Sure thing" and the "Gamble" in this case?

Indifferent point: Inches

Please indicate whether your preference would be different if other attribute levels changed?

Yes () No ()

PART II: DETERMINING UTILITIES OF QUANTITATIVE ATTRIBUTES

ATTRIBUTE # 2: Maximum throughput
Range: 0.02-11 Mbps

STEP 1:

If you have two ways to win a portable data terminal (PDT) by:

1- Entering a gamble in which there is:

A 50 % chance to win a "PDT" with a max. throughput of 0.02 Mbps

A 50 % chance to win a "PDT" with a max. throughput of 11 Mbps

OR

2- Receiving a "PDT" with a certain max. throughput (sure thing!)

What would be the PDT's max. throughput that leaves you indifferent between the "Sure thing" and the "Gamble"?

Indifferent point : Mbps (Please call it *Y*)

STEP 2:

If the gamble rules changed as follows:

A 50 % chance to win a PDT with 0.02 max. throughput

A 50 % chance to win a PDT with *Y* max. throughput (from step 1)

What would be the PDT's max. throughput that leaves you indifferent between the "Sure thing" and the "Gamble" in this case?

Indifferent point : Mbps

STEP 3:

If the gamble rules changed again as follows:

A 50 % chance to win a PDT with a max. throughput of *Y* Mbps

A 50 % chance to win a PDT with a max. throughput of 11 Mbps

What would be the PDT's max. throughput that leaves you indifferent between the "Sure thing" and the "Gamble" in this case?

Indifferent point : Mbps

Please indicate whether your preference for this attribute would be different if other attribute levels changed?

Yes ()

No ()

PART II: DETERMINING UTILITIES OF QUANTITATIVE ATTRIBUTES**ATTRIBUTE # 4: Base RAM**

Range: 128 KB-16 MB

STEP 1:

If you have two ways to win a portable data terminal (PDT)

1- Entering a gamble in which there is:**A 50 % chance to win a PDT with a Base RAM of 128 KB****A 50 % chance to win a PDT with a Base RAM of 16 MB**

OR

2- Receiving a PDT with a certain Base RAM (sure thing !)

What would be the PDT 's Base RAM that leaves you indifferent between the "Sure thing" and the "Gamble"?

Indifferent point : KB/MB (Please call it Y)**STEP 2:**

If the gamble rules changed as follows:

A 50 % chance to win a PDT with Base RAM of 128 KB**A 50 % chance to win a PDT with Y KB/MB (from step 1)**

What would be the PDT 's Base RAM that leaves you indifferent between the "Sure thing" and the "Gamble" in this case?

Indifferent point : KB/MB**STEP 3:**

If the gamble rules changed again as follows:

A 50 % chance to win a PDT with a Base RAM of Y KB/MB**A 50 % chance to win a PDT with a Base RAM of 16 MB**

What would be the PDT Base RAM that leaves you indifferent between the "Sure thing" and the "Gamble" in this case?

Indifferent point : KB/MB

Please indicate whether your preference would be different if other attribute levels changed?

Yes ()

No ()

PART II: DETERMINING UTILITIES OF QUANTITATIVE ATTRIBUTES

ATTRIBUTE # 5: Maximum RAM
Range: 1MB-64 MB

STEP 1:

If you have two ways to win a portable data terminal (PDT) by:

1- Entering a gamble in which there is:

A 50 % chance to win a PDT with a Max. RAM of 1MB
A 50 % chance to win a PDT with a Max. RAM of 64 MB

OR

2- Receiving a PDT with a certain Base RAM (sure thing !)

What would be the PDT 's **Max. RAM** that leaves you indifferent between the "Sure thing" and the "Gamble"?

Indifferent point : MB (Please call it Y)

STEP 2:

If the gamble rules changed as follows:

A 50 % chance to win a PDT with Max. RAM of 1 MB
A 50 % chance to win a PDT with Y MB (from step 1)

What would be the PDT 's **Max. RAM** that leaves you indifferent between the "Sure thing" and the "Gamble" in this case?

Indifferent point : /MB

STEP 3:

If the gamble rules changed again as follows:

A 50 % chance to win a PDT with a Max. RAM of Y MB
A 50 % chance to win a PDT with a Max. RAM of 64 MB

What would be the PDT **Max. RAM** that leaves you indifferent between the "Sure thing" and the "Gamble" in this case?

Indifferent point : MB

Please indicate whether you preference would be different if other attribute levels changed?

Yes () No ()

PART II: DETERMINING UTILITIES OF QUANTITATIVE ATTRIBUTES**ATTRIBUTE # 6: Hard drive/PC card
Range: 1MB- 4 MB****STEP 1:**

If you have two ways to win a portable data terminal (PDT) by:

1- Entering a gamble in which there is:

- A 50 % chance to win a PDT with a Hard drive/PC card of 1 MB**
- A 50 % chance to win a PDT with a Hard drive/PC card of 4 MB**

OR

2- Receiving a reader with a certain Hard drive size (sure thing !)

What would be the PDT 's Hard drive/PC card size that leaves you indifferent between the "Sure thing" and the "Gamble"?

Indifferent point : MB (Please call it Y)

STEP 2:

If the gamble rules changed as follows:

- A 50 % chance to win a PDT with Hard drive/PC card of 1 MB**
- A 50 % chance to win a PDT with Y MB (from step 1)**

What would be the PDT 's Hard drive/PC card size that leaves you indifferent between the "Sure thing" and the "Gamble" in this case?

Indifferent point : MB

STEP 3:

If the gamble rules changed again as follows:

- A 50 % chance to win a PDT with a Hard drive/PC card of Y MB**
- A 50 % chance to win a PDT with a Hard drive/PC card of 16 MB**

What would be the PDT's Hard drive/PC card size that leaves you indifferent between the "Sure thing" and the "Gamble" in this case?

Indifferent point : MB

Please indicate whether you preference would be different if other attribute levels changed?

Yes ()

No ()

PART II: DETERMINING UTILITIES OF QUANTITATIVE ATTRIBUTES**ATTRIBUTE # 8: Number of keyboard keys
Range: 17-56****STEP 1:**

If you have two ways to win a portable data terminal (PDT) by:

1- Entering a gamble in which there is:

A 50 % chance to win a PDT with a keyboard of 17 keys

A 50 % chance to win a PDT with a keyboard of 56 keys

OR

2- Receiving a PDT with a certain number of keyboards (sure thing !)

What would be the PDT 's number of keyboard keys that leaves you indifferent between the "Sure thing" and the "Gamble"?

Indifferent point : keys (Please call it Y)

STEP 2:

If the gamble rules changed as follows:

A 50 % chance to win a PDT with keyboard of 17 keys

A 50 % chance to win a PDT with Y keys (from step 1)

What would be the reader's number of keyboard keys that leaves you indifferent between the "Sure thing" and the "Gamble" in this case?

Indifferent point : Keys

STEP 3:

If the gamble rules changed again as follows:

A 50 % chance to win a PDT with a keyboard of Y keys

A 50 % chance to win a PDT with a keyboard of 56 keys

What would be the PDT's number of keys that leaves you indifferent between the "Sure thing" and the "Gamble" in this case?

Indifferent point : keys

Please indicate whether you preference would be different if other attribute levels changed?

Yes ()

No ()

PART II: DETERMINING UTILITIES OF QUANTITATIVE ATTRIBUTES**ATTRIBUTE # 9: Weight including battery
Range: 7-44 Oz****STEP 1:**

If you have two ways to win a portable data terminal (PDT) by:

1- Entering a gamble in which there is:

A 50 % chance to win a PDT with a weight of 7 Oz

A 50 % chance to win a PDT with a weight of 44 Oz

OR

2- Receiving a PDT with a certain number of keyboards (sure thing !)

What would be the PDT's weight that leaves you indifferent between the "Sure thing" and the "Gamble"?

Indifferent point : Oz (Please call it Y)

STEP 2:

If the gamble rules changed as follows:

A 50 % chance to win a PDT with weight of 7 Oz

A 50 % chance to win a PDT with weight of Y Oz (from step 1)

What would be the PDT 's weight that leaves you indifferent between the "Sure thing" and the "Gamble" in this case?

Indifferent point : Oz

STEP 3:

If the gamble rules changed again as follows:

A 50 % chance to win a PDT with a weight of Y Oz

A 50 % chance to win a PDT with a weight of 44 Oz

What would be the PDT's weight that leaves you indifferent between the "Sure thing" and the "Gamble" in this case?

Indifferent point : Oz

Please indicate whether you preference would be different if other attribute levels changed?

Yes ()

No ()

PART II: DETERMINING UTILITIES OF QUANTITATIVE ATTRIBUTES**ATTRIBUTE # 10: Battery life
Range: 8-100 hours****STEP 1:**

If you have two ways to win a portable data terminal (PDT) by:

1- Entering a gamble in which there is:

- A 50 % chance to win a PDT with a battery life of 8 hours**
- A 50 % chance to win a PDT with a battery life of 100 hours**

OR

2- Receiving a PDT with a certain battery life (sure thing !)

What would be the PDT's battery life that leaves you indifferent between the "Sure thing" and the "Gamble"?

Indifferent point : hours (Please call it **Y)**

STEP 2:

If the gamble rules changed as follows:

- A 50 % chance to win a PDT with battery life of 8 hours**
 - A 50 % chance to win a PDT with battery life of Y hours**
- What would be the PDT's battery life that leaves you indifferent between the "Sure thing" and the "Gamble" in this case?

Indifferent point : hours

STEP 3:

If the gamble rules changed again as follows:

- A 50 % chance to win a PDT with a battery life of Y hours**
- A 50 % chance to win a PDT with a battery life of 100 hours**

What would be the PDT's battery life that leaves you indifferent between the "Sure thing" and the "Gamble" in this case?

Indifferent point : hours

Please indicate whether your preference would be different if other attribute levels changed?

Yes () No ()

PART II: DETERMINING UTILITIES OF QUANTITATIVE ATTRIBUTES**ATTRIBUTE # 11: Technology purchase cost
Range: \$1,075-\$6,500****STEP 1:**

If you have two ways to win a portable data terminal (PDT) by:

1- Entering a gamble in which there is:

- A 50 % chance you pay \$1,075**
- A 50 % chance you pay \$6,500**

OR

2- Paying a certain fixed amount of money (sure thing !)

What would be the **fixed amount of money** that leaves you indifferent between the "Sure thing" and the "Gamble"?

Indifferent point : \$ (Please call it Y)

STEP 2:

If the gamble rules changed as follows:

- A 50 % chance to pay \$6,500**
- A 50 % chance to pay \$ Y (from step 1)**

What would be the **fixed amount of money** that leaves you indifferent between the "Sure thing" and the "Gamble" in this case?

Indifferent point :\$

STEP 3:

If the gamble rules changed again as follows:

- A 50 % chance to pay \$ Y**
- A 50 % chance to pay \$ 1,075**

What would be the **fixed amount of money** that leaves you indifferent between the "Sure thing" and the "Gamble" in this case?

Indifferent point :\$

Please indicate whether your preference would be different if other attribute levels changed?

Yes () No ()

PART II: DETERMINING UTILITIES OF QUANTITATIVE ATTRIBUTES**ATTRIBUTE # 12: Technology operating cost****STEP 1:**

If you have two ways to win a portable data terminal (PDT) by:

1- Entering a gamble in which there is:

A 50 % chance you pay \$200

A 50 % chance you pay \$2,500

OR

2- Paying a certain fixed amount of money (sure thing !)

What would be the **fixed amount of money** that leaves you indifferent between the "Sure thing" and the "Gamble"?

Indifferent point : \$ (Please call it **Y)**

STEP 2:

If the gamble rules changed as follows:

A 50 % chance to pay \$2,500

A 50 % chance to pay \$ Y (from step 1)

What would be the **fixed amount of money** that leaves you indifferent between the "Sure thing" and the "Gamble" in this case?

Indifferent point : \$

STEP 3:

If the gamble rules changed again as follows:

A 50 % chance to pay \$ Y

A 50 % chance to pay \$200

What would be the **fixed amount of money** that leaves you indifferent between the "Sure thing" and the "Gamble" in this case?

Indifferent point : \$

Please indicate whether your preference would be different if other attribute levels changed?

Yes ()

No ()

PART II: DETERMINING UTILITIES OF QUANTITATIVE ATTRIBUTES

Q1-On a scale of “0” to “10”, where (0) is the “least preferred” and (10) is the “most preferred”, please indicate your preference for the following technology attributes:

	Your preference
Technology writing ability	
Technology <u>with</u> writing ability	()
Technology <u>without</u> writing ability	()
Operating system	
Dos	()
Windows	()
Built in wireless capability	
Technology with wireless capability	()
Technology without wireless capability	()
Technology security	
Secured technology	()
Unsecured technology	()
Data carrier environmental resistance	
Bar code labels	
Paper	()
Plastic	()
RFID tags	
Coin (ABS) injection housing	()
Glass housing	()
Plastic housing	()
PDT ruggedized characteristics	
Available	()
Unavailable	()
Data entry method	
Keyboard	()
Touch screen	()

Need for a line of sight to read
Technology that **must** have a line of sight ()
Technology that **does not require** line of sight ()

Adverse effect (anti collision, metal effect)
Technology of **high** possibility of facing adverse effect ()
Technology of **low** possibility of facing adverse effect ()

Q2- On a risk level scale of "0" to "1", where "0" represents the "Highest level of risk", and "1" represents "No risk at all", Please indicate the level of risk associated with:

Bar code system ()
RFID system ()

PART IV: Determining the objectives interaction weights using indifference probabilities.

If you have three hypothetical options defined in terms of lottery #1 and #2 in the following figures. Options A and C are fixed and represent two extremes in which one objective is at the best level and the other attribute is at the worst level. Option B represents a gamble in which it is possible to get both objectives either in their best or worst level together. Your trade-offs among objectives reflect the objectives weights.

Please determine your preference as for what probability p are you indifferent between A and B (P_c). This measures your willingness of risk losing everything on the technology capability for a chance of gaining everything in terms of technology reliability. Repeat the process by comparing B and C to obtain (P_r). This measures your willingness of risk losing everything on the technology reliability for a chance of gaining everything in terms of technology capability.

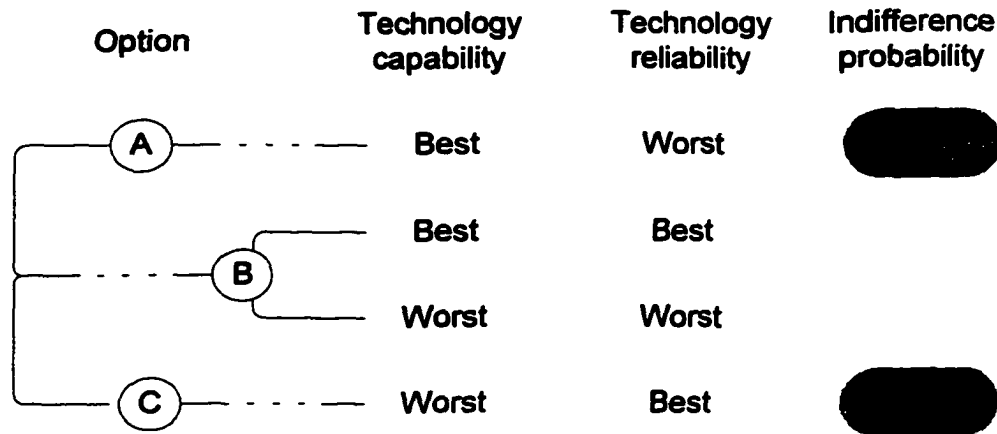

Question 1: Please determine your indifference probabilities for technology capability and reliability.

Question 2: Please determine your indifference probabilities for technology cost and risk.

Option	Technology cost	Technology risk	Indifference probability
A	Best	Worst	<input type="text"/>
B	Best	Best	<input type="text"/>
	Worst	Worst	<input type="text"/>
C	Worst	Best	<input type="text"/>

Question 3: Please determine your indifference probabilities for the technical merit and economic merit objectives

Option	Technical merit	Economic merit	Indifference probability
A	Best	Worst	<input type="text"/>
B	Best	Best	<input type="text"/>
	Worst	Worst	<input type="text"/>
C	Worst	Best	<input type="text"/>

**End of the survey
Thank you!**

APPENDIX F. UTILITY CURVES AND EQUATIONS FOR QUANTITATIVE ATTRIBUTES IN OVERALL SAMPLE

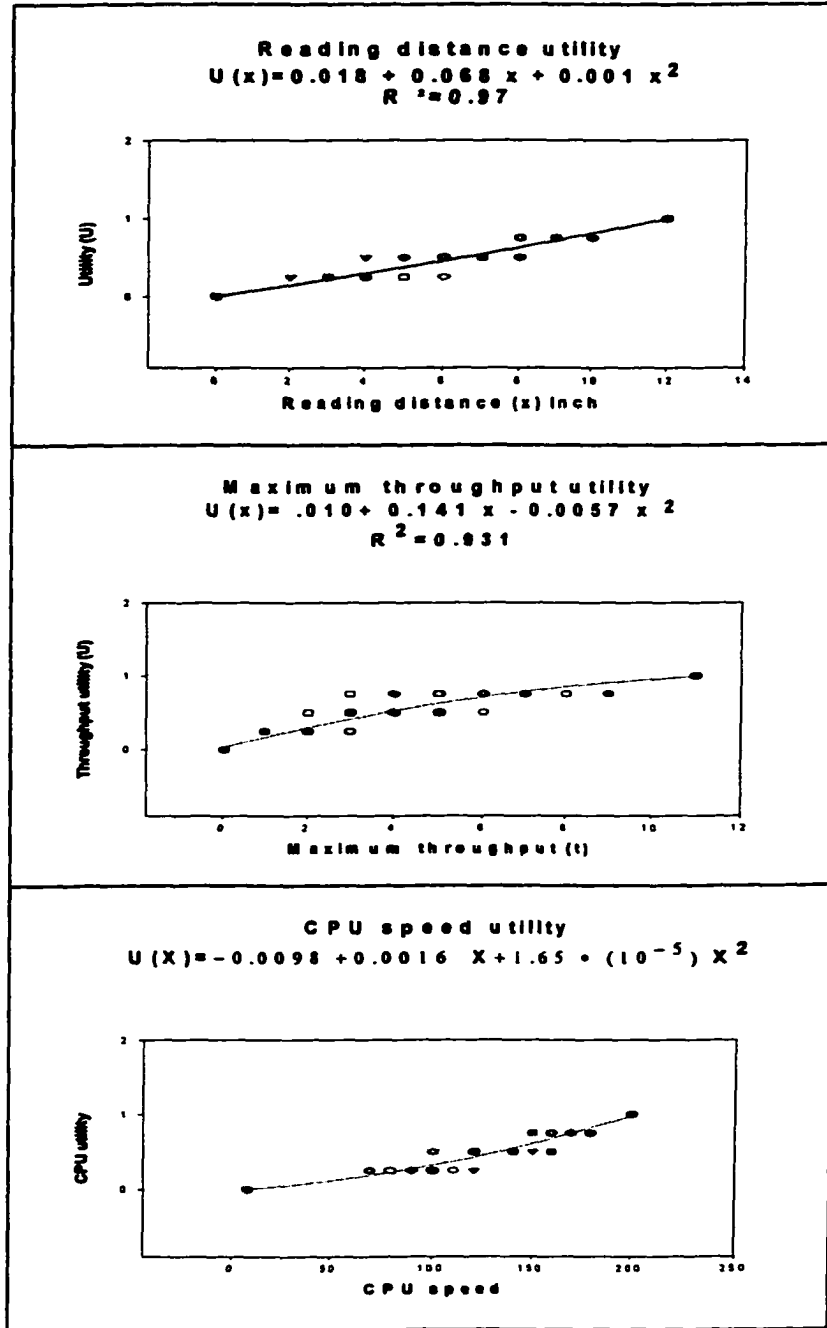

Figure 37. Utility curves for quantitative attributes in overall sample

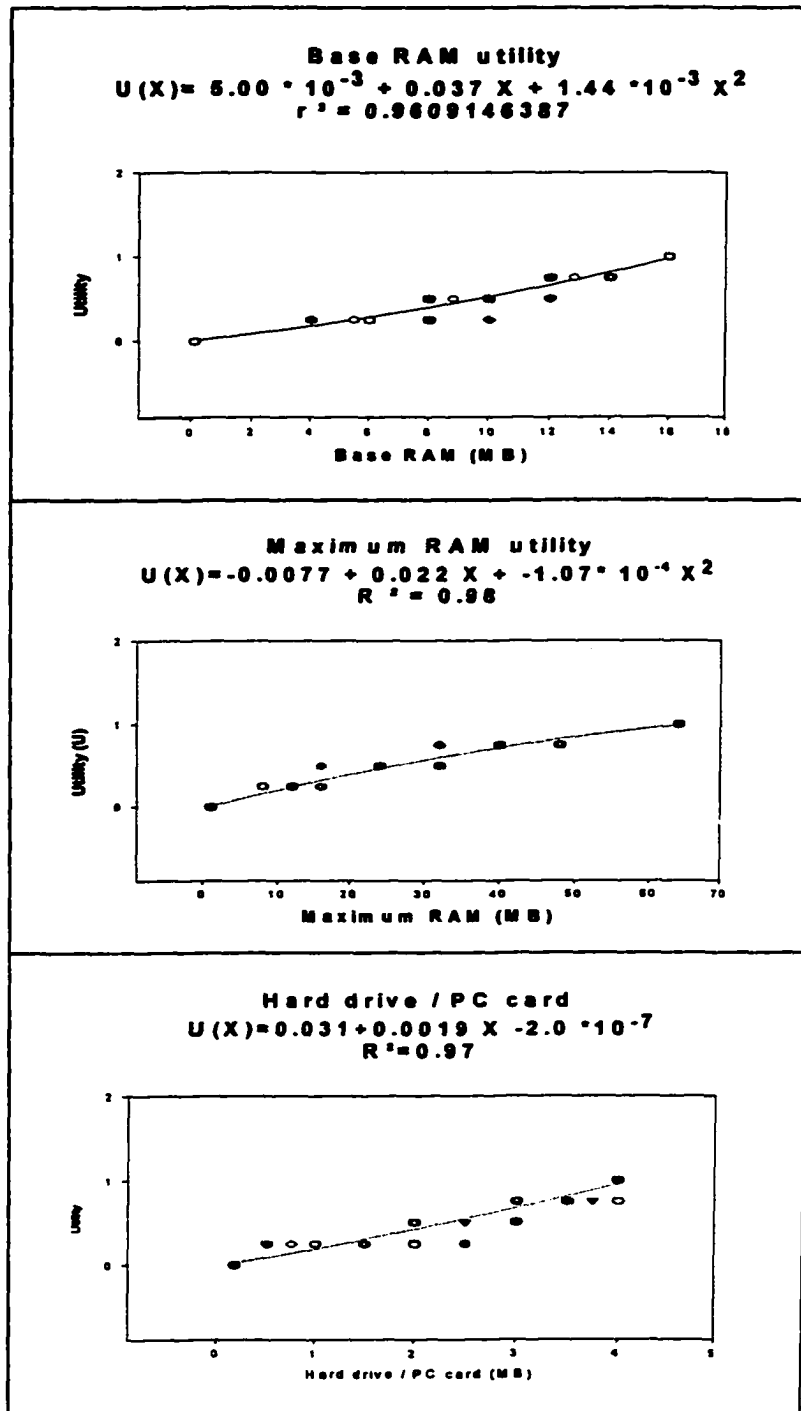

Figure 37 continued

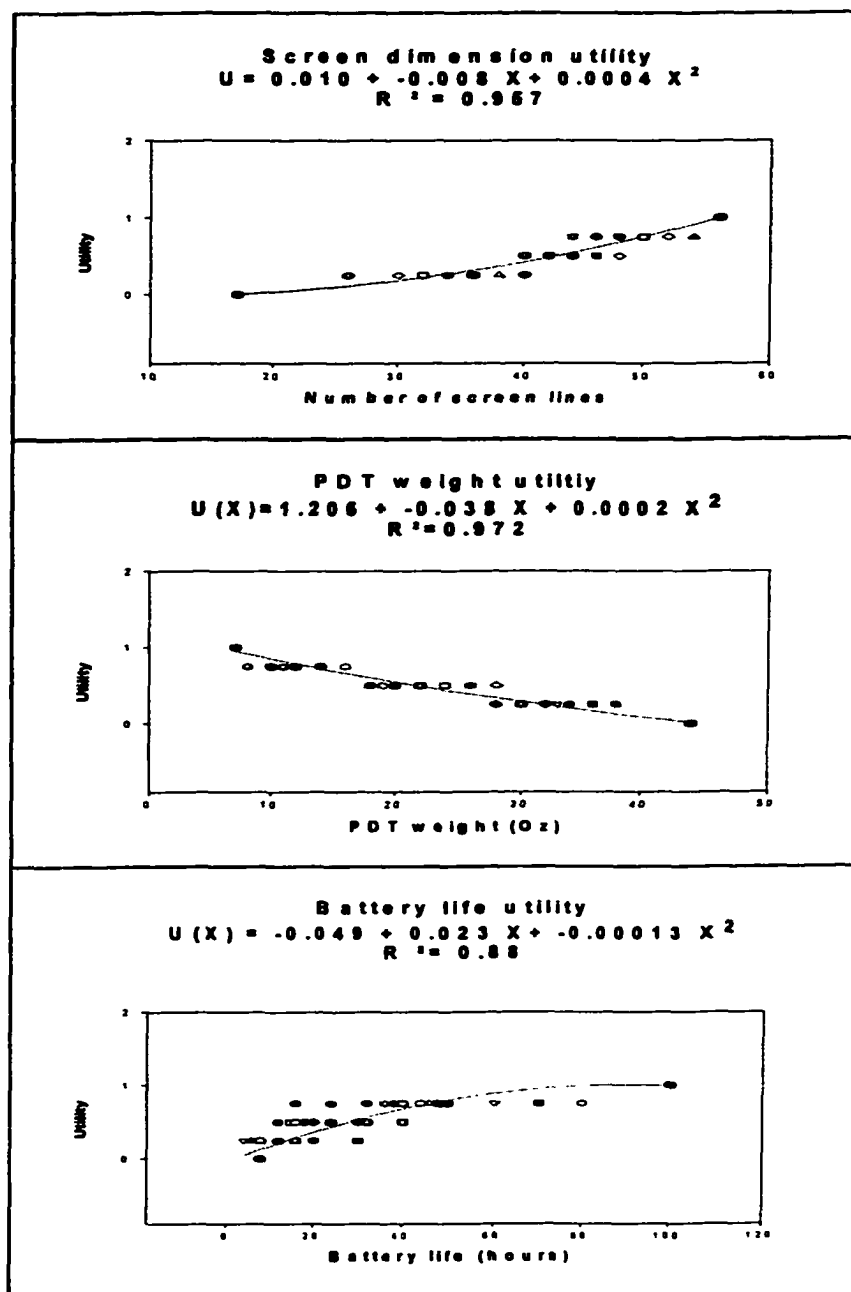

Figure 37 continued

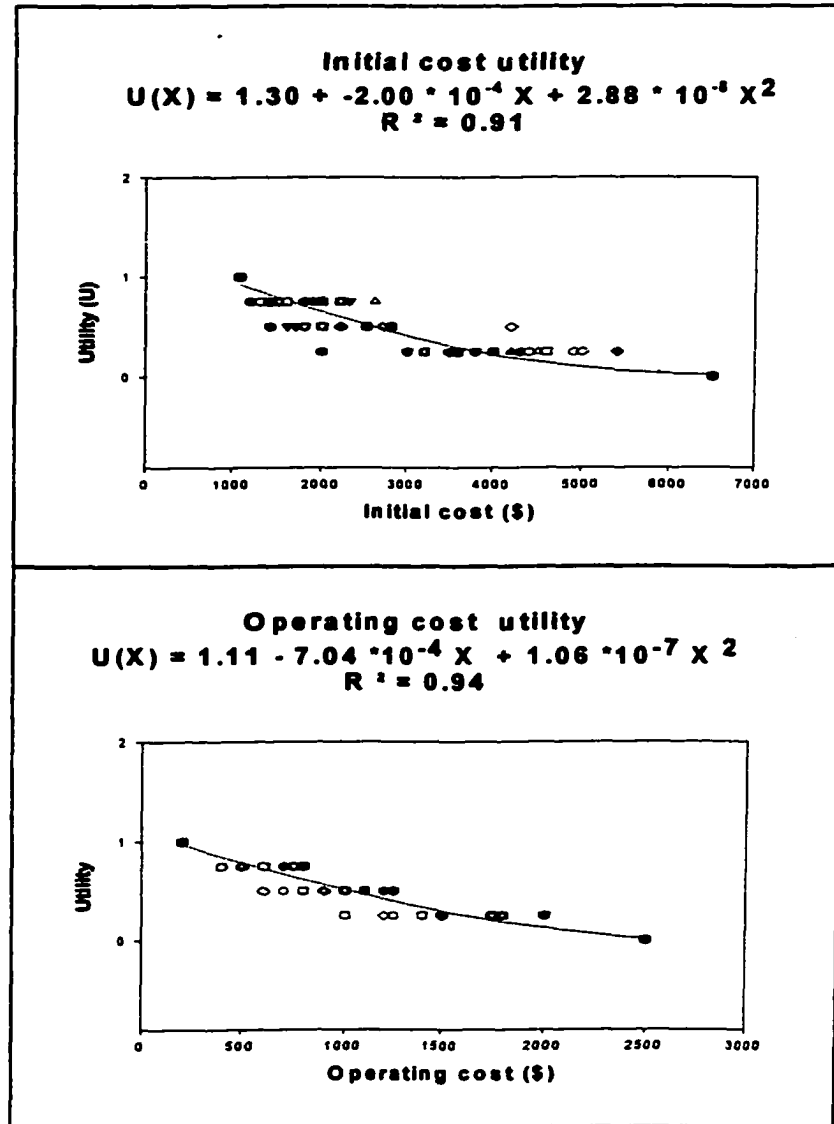

Figure 37 continued

APPENDIX G. SUMMARY OF INTERMEDIATE AND AGGREGATE UTILITY CALCULATIONS

Table 9. Summary of intermediate and aggregate utility calculations for ITP at IDOT, private labs, and in the overall sample

IT in private labs										
System capability utility	0.187	0.581	0.678	0.325	0.219	0.203	0.685	0.335	0.346	0.223
System reliability utility	0.527	0.651	0.651	0.651	0.527	0.570	0.570	0.570	0.446	0.446
Technical merit utility	0.209	0.489	0.548	0.331	0.227	0.231	0.508	0.306	0.265	0.203
Cost utility	0.942	0.369	0.611	0.675	0.787	0.421	0.142	0.150	0.125	0.295
Risk utility	0.588	0.588	0.588	0.588	0.588	0.788	0.788	0.788	0.788	0.788
Economic merit utility	0.988	0.491	0.658	0.703	0.780	0.598	0.497	0.412	0.399	0.508
ITP in IDOT										
System capability utility	0.216	0.598	0.689	0.337	0.252	0.223	0.625	0.329	0.318	0.218
System reliability utility	0.520	0.659	0.659	0.659	0.520	0.575	0.575	0.575	0.436	0.436
Technical merit utility	0.252	0.553	0.616	0.374	0.276	0.272	0.539	0.342	0.293	0.230
Cost utility	0.948	0.343	0.596	0.660	0.777	0.450	0.149	0.158	0.131	0.314
Risk utility	0.578	0.578	0.578	0.578	0.578	0.840	0.840	0.840	0.840	0.840
Economic merit utility	0.830	0.370	0.562	0.611	0.700	0.614	0.419	0.425	0.407	0.525
Total aggregate utility	0.449	0.566	0.655	0.481	0.431	0.405	0.565	0.410	0.366	0.349
All ITP										
System capability utility	0.199	0.594	0.699	0.340	0.241	0.223	0.705	0.357	0.362	0.240
System reliability utility	0.522	0.655	0.655	0.655	0.522	0.574	0.574	0.574	0.441	0.441
Technical merit utility	0.229	0.519	0.585	0.358	0.253	0.259	0.546	0.339	0.292	0.226
Cost utility	0.931	0.356	0.588	0.652	0.766	0.419	0.131	0.139	0.114	0.287
Risk utility	0.583	0.583	0.583	0.583	0.583	0.814	0.814	0.814	0.814	0.814
Economic merit utility	0.849	0.431	0.599	0.741	0.815	0.590	0.404	0.409	0.393	0.505
Total aggregate utility	0.430	0.548	0.634	0.496	0.438	0.383	0.564	0.399	0.357	0.335

Table 10. Summary of intermediate and aggregate utility calculations for technicians at IDOT, private labs, and in the overall sample

Technicians in private labs										
System capability utility	0.252	0.553	0.647	0.338	0.265	0.245	0.628	0.328	0.359	0.221
System reliability utility	0.563	0.678	0.678	0.678	0.563	0.541	0.541	0.541	0.427	0.427
Technical merit utility	0.289	0.530	0.594	0.381	0.297	0.277	0.528	0.332	0.315	0.230
Cost utility	0.943	0.298	0.567	0.635	0.759	0.483	0.161	0.171	0.141	0.337
Risk utility	0.521	0.521	0.521	0.521	0.521	0.697	0.697	0.697	0.697	0.697
Economic merit utility	0.885	0.434	0.621	0.669	0.756	0.620	0.408	0.414	0.395	0.524
Technicians in IDOT										
System capability utility	0.274	0.587	0.700	0.356	0.304	0.282	0.613	0.352	0.362	0.239
System reliability utility	0.542	0.683	0.683	0.683	0.542	0.549	0.549	0.549	0.407	0.407
Technical merit utility	0.342	0.571	0.630	0.451	0.356	0.349	0.508	0.383	0.317	0.263
Cost utility	0.948	0.274	0.553	0.622	0.750	0.509	0.167	0.178	0.147	0.354
Risk utility	0.486	0.486	0.486	0.486	0.486	0.743	0.743	0.743	0.743	0.743
Economic merit utility	0.758	0.313	0.498	0.542	0.626	0.677	0.488	0.492	0.474	0.591
All technicians										
System capability utility	0.231	0.588	0.699	0.351	0.270	0.253	0.685	0.362	0.377	0.246
System reliability utility	0.542	0.670	0.670	0.670	0.542	0.558	0.558	0.558	0.430	0.430
Technical merit utility	0.290	0.554	0.621	0.410	0.312	0.308	0.557	0.371	0.328	0.258
Cost utility	0.930	0.317	0.563	0.629	0.750	0.451	0.140	0.149	0.122	0.309
Risk utility	0.504	0.504	0.504	0.504	0.504	0.720	0.720	0.720	0.720	0.720
Economic merit utility	0.821	0.401	0.569	0.729	0.603	0.620	0.429	0.434	0.417	0.532

APPENDIX H: SUMMARY OF THE MAUM CALCULATIONS

The purpose of this Appendix is to show an example of the model calculations. The main steps in the MAUM used in this study are described below (refer to figure 39).

1-FORM THE MODEL STRUCTURE

Step 1: Identify all the technology devices to be evaluated (for example system #1 to system # 10). Only system # 3 is used in this example.

Step 2: Determine the evaluation objectives (Technical, economic, and low-risk merit). Objectives should be set in a hierarchy ending with option attributes (reading distance, writing ability,....etc). Only select attributes that are relevant and able to distinguish among different technology systems (column B).

2-DETERMINE OBJECTIVE AND ATTRIBUTE WEIGHTS

Step 3: Assign attribute and objective weights.

For attribute weights:

- Under each objective, assign an importance weight for each attribute on a 100-point scale. Column G in the attached spreadsheet shows the average attribute importance ratings determined by the evaluators. These ratings come from answering questions in part I in Appendix E. For example, the average rating for the reading speed attribute by the IT group is 77.50 (see G7 in the spreadsheet).
- Weights are to be normalized for each attribute by dividing each single attribute weight by the sum of all attribute weights in the set. For example, the reading distance attribute weight is calculated by dividing $77.5 / 803.13 = 0.096$ (see H7 in the attached spreadsheet).
- Follow the same procedure to calculate the rest of attribute weights.

For objective weights:

- Objective weights can be calculated using the indifference probabilities obtained from part IV in Appendix E. Figure 38 shows the question used to solicit the indifference probabilities for technology capability and reliability. E6 and E22 in the attached spreadsheet show that the average

indifference probabilities for technology capability and reliability by the IT group are 0.444 and 0.213, respectively.

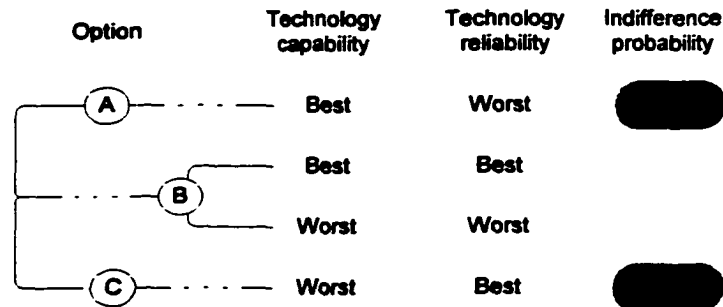

Figure 38. Example of indifference probabilities calculations

Then the interaction weights for capability and reliability objectives are calculated using the following formulas:

$$W_c = (1 - p_c - p_r) / p_r$$

$$W_r = (1 - p_c - p_r) / p_c$$

Where p_c , and p_r are the indifference probabilities for technology capability and reliability. W_c and W_r are capability and reliability interaction weights, respectively.

For example, the capability and reliability interaction weights shown in F6 and F22 in the attached spreadsheet are calculated as follows:

$$W_c = (1 - 0.444 - 0.213) / 0.213 = 1.610 \text{ (see F6)}$$

$$W_r = (1 - 0.444 - 0.213) / 0.444 = 0.773 \text{ (see F22)}$$

- Using the indifference probabilities for technology cost and risk (0.819 in E32, and 0.388 in E37), repeat the same type of previous calculations to obtain cost and risk weights (-0.532 and -0.253 in F32 and F37, respectively).
- Using the indifference probabilities for technical and economic merit (0.881 in C4, and 0.319 in C31), repeat the same type of previous calculations to obtain technical and economic merit weights (-0.627, and -0.227 in D4 and D31, respectively).

3-DETERMINING ATTRIBUTE UTILITIES

Step 4: For each single attribute, assign a utility that measures the system performance on that attribute. A single attribute utility can be determined depending on whether the attribute is quantitative or qualitative.

- For quantitative attributes:

- To construct an attribute utility function, the evaluator has to make a series of choices about a sure thing and lottery (refer to part II in Appendix E). A curve is fitted for each utility function and used to calculate the attribute utility value for each system. Equation coefficients are found in columns J, K, and L. For example, the reading distance utility function can be read from J7, K7, and L7 as follows:

$$U (\text{reading distance attribute}) = 0.009 + 0.0664 X + 0.0013 X^2$$

Where X is the reading distance measured in inches.

By substituting X= 11.6 inch in the previous equation, the utility of (11.6 inch) is 0.955 (see M7 in the attached spread sheet). Calculations for the rest of attribute utilities are performed the same way and can be found in column N.

- For qualitative attributes:

- Direct ratings on a 10- point scale are used because it is not possible to draw curves for qualitative attributes. Column M contains qualitative attribute utilities. For example, M23 in the attached spreadsheet shows that the average utility for technology security is 0.638. This comes from asking the evaluators a question like:

How would you rate?

	Utility
a-A Secured technology (encryption)	()
b-An Unsecured technology (no encryption)	()

- Questions designed to obtain the evaluator’s qualitative attribute utilities are found in part III in appendix E.

4-MODEL CALCUALTION

Step 5: Use the additive rule to calculate lower level objective utilities (capability, reliability, cost, and low-risk utilities). Use the multiplicative rule to combine these objectives into technical merit, economic merit, and aggregate utilities. This is done as follows:

- The weighted utility for each attribute is calculated by multiplying the utility attribute by its assigned weight. For example, the weighted utility for the reading distance attributes is obtained by multiplying the reading distance utility (0.955 in M7) by the reading distance attribute weight (0.096 in H7). The result is found in N7(0.092).
- Do the same type of calculations for all attributes in the analysis.
- For each system and under each objective, take a weighted average of the utilities assigned to the system attributes. The additive rule is described as follows:

$$U(x) = \sum_i^n w_i u_i(x_i)$$

Where:

X: The technology system

U(x): The aggregate utility of x

W_i: The objective weight

U_i(x): The single utility of attribute i for system x

- Utilities for lower level objectives are obtained by summing all weighted attribute Utilities that achieve these objective. These weighted utilities give a measure of the system performance in relation to that objective (see column N). For example, the system capability utility are calculated by summing N7:N19 to get 0.578 (see N21 in the attached spreadsheet).
- Do the same steps to calculate the system reliability, cost, and low risk utilities (see N29, N32, and N37).

- Use the multiplicative rule to calculate the technical merit, economic merit, and aggregate utilities. The multiplicative rule can be described as follows:

$$U(x) = \left[\prod_{i=1}^n [1 + w_i^* u_i(x_i)] - 1 \right] / \left[\prod_{i=1}^n [1 + w_i^*] - 1 \right]$$

Where:

X : The technology system

$U(x)$: The aggregate utility of x

W_i : The objective weight

$U_i(x)$: The single utility of attribute i for system x

For example, the technical merit utility is calculated by combining the system capability utility (0.578 in N21) with system reliability utility (0.659 in N29), using capability weight (1.610 in F6) and reliability weight (0.773 in F22) as follows:

$$U(\text{technical merit}) = \frac{[(1+1.61 \cdot 0.578) \cdot (1+0.773 \cdot 0.659) - 1]}{[(1+1.61) \cdot (1+0.773) - 1]} = 0.528 \text{ (see N30)}$$

- Use the same procedure to combine the system cost utility (0.595 in N36) and low-risk utility (0.588 in N38) to obtain the economic merit utility (0.643 in N39).
- Use the same procedure to combine the technical merit utility (0.528 in N30) and economic merit utility (0.643 in N39) to obtain the system aggregate utility (0.602 in N40).

5-SYSTEMS RANKING AND SENSITIVITY ANALYSIS

Step 6: Based on the calculated aggregate utilities, develop a ranking of the systems (if you have more than one system).

Step 7: Perform sensitivity analysis to see how robust the decision is to the changes in the model parameters and assumptions.

Figure 39. Example of the model calculation

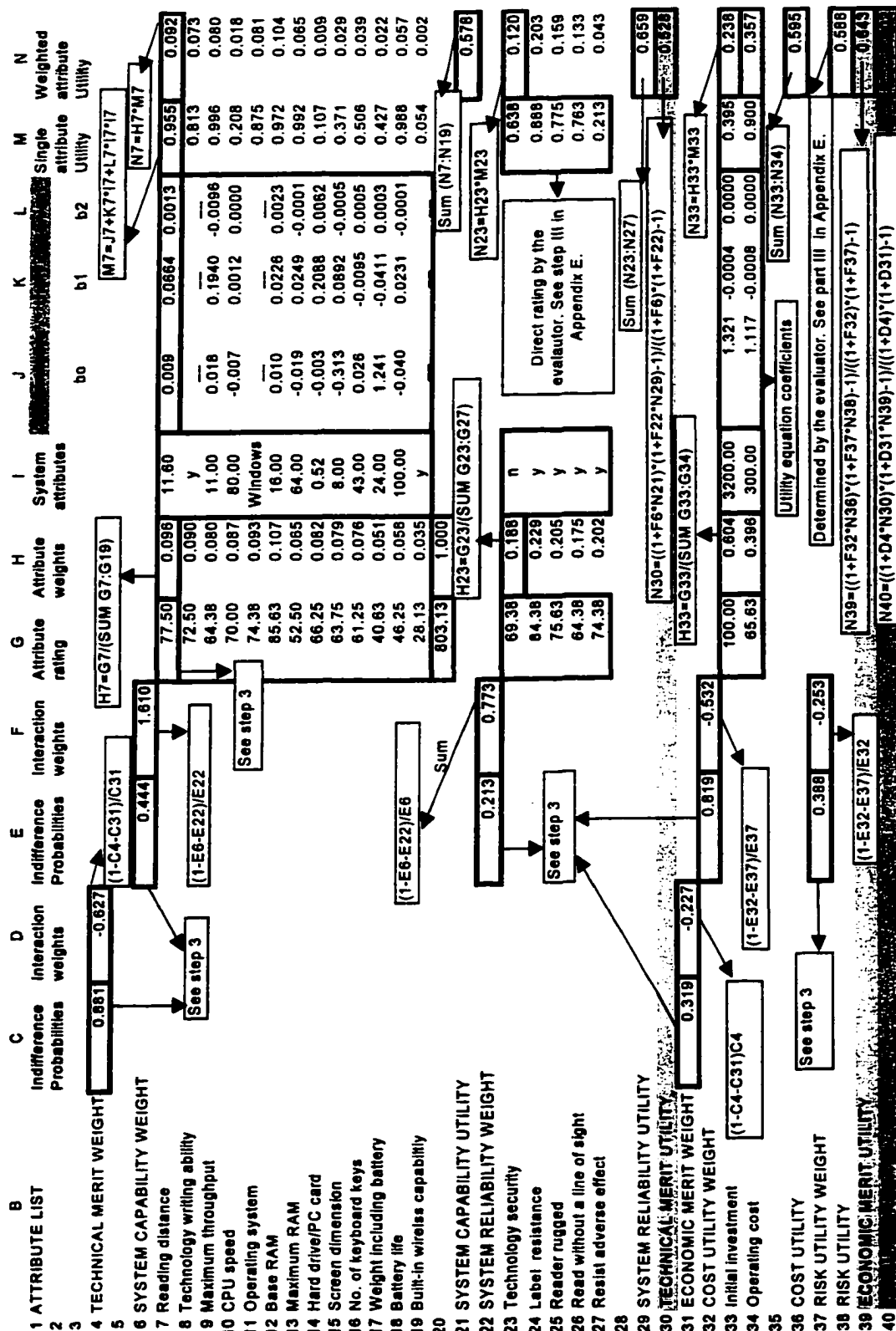

REFERENCES CITED

Adam Russ. (1990). Sourcebook of automatic identification and data collection. Van Nostrand Reinhold, New York.

Bachh, M. (1989). "Application of bar code technology for construction inventory control." A paper submitted in partial fulfillment of the requirements for the degree of Master of Science, Iowa State University, Ames, Iowa.

"Bar code for beginners." (2001)
<http://www.systemid.com/education/beginners.asp>.

"Bar code symbologies." (2001)
www.taltech.com/resources/intro_to_bc/bcsymbol.htm.

"Bar code history page." (2001)
<http://www.adams1.com/pub/russadam/history>

Bard, J. F., Feinberg, A., and Zimmerman, W. F. (1889). "Designing large scale multiattribute system." In handbook of technology management, D.K. Kacaoglu, Ed. New York.

Blakey, L., (1990). "Bar codes: Prescription for precision, performance, and productivity." Journal of Construction Engineering and Management, ASCE, 116(3), 468-477.

Buchanan J. T. (1982). Discrete and dynamic decision analysis. John Wiley & Sons, New York.

Byrnes, P. James (1998). The nature and development of decision making. Lawrence Erlbaum Associates, Publishers, New jersey.

Campbell, D. T. (1975). "Degrees of freedom and case the case study." Comparative Political Studies, 178-193.

Canada R. John, Sullivan G. William (1989). Economics and multiattribute evaluation of advanced manufacturing systems. Prentice Hall, Englewood Cliffs, New Jersey.

Chang, L., Hancher, D., Napier, T., and Kaponek, R. (1987). "Methods to identify and assess new building technology." Journal of Construction Engineering and Management, ASCE, 114 (3), 408-425.

Chao, L. and Skibniewski, M. (1995). "Decision analysis for new construction technology implementation." *Civil Engineering Systems*, Vol. 12, 67-82.

Chao, L. and Skibniewski, M. (1998). "Fuzzy logic for evaluating alternatives construction technology." *Journal of Construction Engineering and Management*, ASCE, July/August.

Clouch J. Donald (1984). *Decision in public and private sectors*. Prentice Hall, Inc., New York.

Cohen Jonathan, 1994. *Automatic identification and data collection systems*. Mc Graw-Hill book company, New York.

Colin E. Bill, (1977). *Quantitative methods for administration*. Richard D. Irwin, Inc., New York.

Cook, T. D. & Campbell, D. T. (1979). *Quasi experimentation: Design and analysis issues for field settings*. Chicago: Rand McNally.

Easton, A. (1973). *Complex managerial decisions involving multiple objectives*. John Wiley, New York.

Edwards Ward, Newman J. Robert (1982). *Mutiattribute evaluation*. Sage Publishers, Beverly Hills.

Feeser, L., (2001). "Information technology for life-cycle in infrastructure management." *Journal of Construction Engineering and Management*, Jan.

Floyd, R. E. (1993). "RFID systems and solutions," *ID Systems*, 13(6), 44-50.

Geoffrion, A. M., Dyer, J.S., and Feinberg, A. (1972). "An interactive approach for multi-criterion optimization with an application to operation of an academic departments" *Management Science*, vol.19, No. 4, 357-368.

Gibson, G., and Lansford, C. (1990). "Electronic Data Interchange in Construction." *Journal of Construction Engineering and Management*, ASCE, 116(4), 727-737.

Glenn W. Lee (1998). The auto ID book. www.ssystemid.com

Golub Lang Andrew (1997). Decision analysis: An integrated approach. John Wiley & Sons.

Goodwin Paul, Wright George (1991). Decision analysis for management judgment John Wiley & Sons.

Halliday, Steve (1999). 125-134 kHz RFID Standards Workshop sponsored by the National Institute of Standards and Technology, November 5.

Jacobs, Bill. (1999). "At last, IT departments can directly track assets to reduce their costs" Automatic ID News.

Jaselskis, E. and Elmisalami, T. 2000. "Radio Frequency Identification Tagging: Applications For the Construction Industry." Construction Industry Institute.

Jaselskis, E. and Jahren Charles 1995. "Radio-Frequency Identification Application In Construction Industry." Journal of Construction Engineering and Management, ASCE, June 189-196.

Jung, Y. and Gibson, E. (1999). "Planning for computer integrated construction." Journal of Computing in Civil Engineering, Vol. 113(4), 217-225.

Jung, Y., Gibson, G., (1999). "Planning for computer integrated construction." Journal of Construction Engineering and Management, October, 217-225.

Kenney L. Ralph, Raiffa Howard (1976). Decisions with multiple objectives: Preferences and value tradeoffs. John Wiley & Sons, New York.

Laborde, M., Sanvido V., (1994). "Introducing new process technologies into construction companies." Journal of Construction Engineering and Management, Vol. 120, No. 3, 488-508.

Laborde, M. and Sanvido, V. (1994). "Introducing new process technologies into construction companies." Journal of Construction Engineering and Management, ASCE, 120(3), 488-508.

Lutz, J., Chang, L., Napier, T. (1989). "Evaluation of new building technology." *Journal of Construction Engineering and Management*, ASCE, 116(2), 281-299.

Mc Clullouch, G. (1994). "2 D bar-code application in construction." *Journal of Construction Engineering and Management*, ASCE, 120 (4), 739-753.

Mitropoulos, P., Tatum, C. B. (2000). "Forces driving adoption of new information technologies." *Journal of Construction Engineering and Management*, Sep./Oct. 340-348.

Mora, B., Vadhavkar, E., and Weber, T. (1999). "Information technology planning framework for large-scale projects." *Journal of Construction Engineering and Management*, Oct., 226-237.

Nord, W. R., Tucker, S. (1987). *Implementing routine and radical innovations*, Lexington Books, Lexington.

Pitz, F.Gordon, Mc Killip Jack (1984). *Decision analysis for program evaluators*. Sage publications, Beverly Hills.

Rasdorf, W. and Herbert, M. (1990) "Bar coding in construction engineering." *Journal of Construction Engineering and Management*, ASCE, 116(2), 261-280.

"RFID (Radio Frequency Identification)." (2001)
www.systemid.com/search/catsearch.asp?category=010215

"RFID Applications." (1998). Motorola Home Page,
<http://www.mot.com>.

Rogers, E. M. (1983). *Diffusion of innovations*, Free Press, New York.

Rosenfeld, Y., Navon, R., and Cohen, L. (1998). "Methodology for prioritizing cost-effective construction technologies." *Journal of Construction Engineering and Management*, ASCE, 124(3), 176-183.

Rutman Leonard (1984). *Evaluation research methods*. Sage Publishers.

Sharp, Kevin R. (1990), Automatic identification: Making it pay. Van Nostrand Reinhold, New York.

Slovic, P. (1987). Perception of risk. *Science*, 236, 280-286.

Stukhart, G. (1989). "Barcodes find increasing use in construction." *Construction Industry Institute News*, 2(2), 1-2.

Stukhart, G. and Lynn, E. (1990). "Bar-Code standardization in industrial construction." *Journal of Construction Engineering and Management*, ASCE, 116(2), 416-431.

Teicholz, P., (1994). "Strategy for computer integrated construction technology." *Journal of Construction Engineering and Management*, Vol. 120, No. 1, 117-131.

Telsor, (no date a). "Automatic Identification with Advanced RFID Technology: Telsor's automatic identification systems are the ideal solution in many ID applications."

Telsor, (no date b). "Automatic Identification Systems with Advanced RFID Technology."

Thompson, S. Mark (1982). Decision analysis for program evaluation. Ballinger publishing company, Massachusetts.

Toole, T. (1998). "Uncertainty and home builders adoption of technological innovations." *Journal of Construction Engineering and Management*, ASCE, 124(4), 323-332.

"Two dimensional bar code page"(2001)
<http://www.adams1.com/pub/russadam/stack.html>)

"What are bar codes?" (2001)
<http://www.in-barcode.com/intro.html>

"What is AIDC?" (2001).<http://www.aimglobal.org/tech>

What is RFID ?" (1998). Motorola, Inc.
<http://www.mot.com/LMPS/Indala/rfid.html>,

Winterfeldt Detlof Von, Edwards ward (1986). Decision analysis and behavioral research, Cambridge University Press.